

play the same focusing role in the synthesis of target crystal structures (supermolecules) that (molecular) syntheses and chirons have in the synthesis of complex natural products (molecules). All these exciting developments project that the challenge for organic chemists in the new millennium will lie in understanding and controlling another type of bond, the hydrogen bond.

1. Jacques, J., Collet, A. and Wilen, S. H., *Enantiomers, Racemates and Resolutions*, Krieger Publishing, Malabar, FL, 1994.

2. Pasteur, L., *Ann. Chim. Phys.*, 1848, **24**, 442.

3. Toda, F. and Shinyama, T., *J. Chem. Soc., Perkin Trans 1*, 1997, 1759–1761.

4. Saigo, K., Kinbara, K. and Kobayashi, Y., *J. Chem. Soc., Perkin Trans 2*, 1998, 1767–1775.

5. Kozsda-Kovács, É., Keserü, G. M., Böcskei, Z., Szilágyi, I., Simon, K., Bertók, B. and Fogassy, E., *J. Chem. Soc., Perkin Trans 2*, 2000, 149–153.

6. Hanessian, S., Saladino, R., Margarita, R. and Simard, M., *Chem. Eur. J.*, 1999, **5**, 2169–2183.

7. Hanessian, S., Simard, M. and Roelens, S., *J. Am. Chem. Soc.*, 1995, **117**, 7630–7645.

8. Hanessian, S., Gomtsyan, A., Simard, M. and Roelens, S., *J. Am. Chem. Soc.*, 1994, **116**, 4495–4496.

9. Ermer, O. and Eling, A., *J. Chem. Soc., Perkin Trans 2*, 1994, 925–943.

10. Hanessian, S., *Total Synthesis of Natural Products: The Chiron Approach*, Pergamon Press, New York, 1983.

11. Desiraju, G. R., *Angew. Chem. Int. Ed. Engl.*, 1995, **34**, 2311–2327.

Ashwini Nangia is in the School of Chemistry, University of Hyderabad, Hyderabad 500 046, India.

Do our maternal and paternal genes pull us in different directions?

Raghavendra Gadagkar

In all diploid organisms such as ourselves, each individual inherits one set of chromosomes from the mother and another set from the father. It is generally assumed that once these chromosomes reach our bodies, they lose any 'memory' of where they came from. However there is evidence that chromosomes (and the genes they contain) sometimes get differentially imprinted as they pass through a male or female body and this imprint may be retained when the chromosomes are passed on to the next generation^{1–6}. There is also evidence that DNA methylation is a mechanism by which chromosomes may acquire such male-specific or female-specific imprints. Differential patterns of DNA methylation are known to lead to different levels of gene expression^{7–10}. What all this means then is that our paternally derived genes and maternally derived genes may behave differently in our bodies even though they may be otherwise identical. To the extent that genes influence our behaviour it may well be that our father's genes and mother's genes pull us in different directions.

In 1992, David Haig¹¹, then at the University of Oxford, pointed out that such a possibility has serious consequences for the standard predictions of

sociobiological theory which is based on the assumption that paternal and maternal genes do not behave differently. Let us consider two examples. In insects that belong to the order Hymenoptera (ants, bees, wasps) females can lay both unfertilized, haploid eggs as well as fertilized, diploid eggs. The fertilized diploid eggs develop into diploid adult females whereas the unfertilized haploid eggs develop into haploid adult males. Since males are haploid, they produce sperm that are clones of each other. The females, being diploid, produce haploid eggs that receive a randomly chosen 50% of the maternal genome. In such haplodiploid insects, two sisters would be related to each other by a coefficient of genetic relatedness r of 0.75 but a female would be related to her offspring by the usual 0.5 (as in diploid species) (Figure 1). In 1964 W. D. Hamilton^{12,13} pointed out that such asymmetries in genetic relatedness should select for altruistic behaviour on the part of females to care for their sisters rather than to produce their own offspring. This is indeed what workers (who are females) in many social insect colonies do. In 1976 Trivers and Hare¹⁴ pointed out that although workers are more closely related to their sisters ($r = 0.75$) they are much less related to their brothers

($r = 0.25$), as compared to their offspring ($r = 0.5$). They predicted there

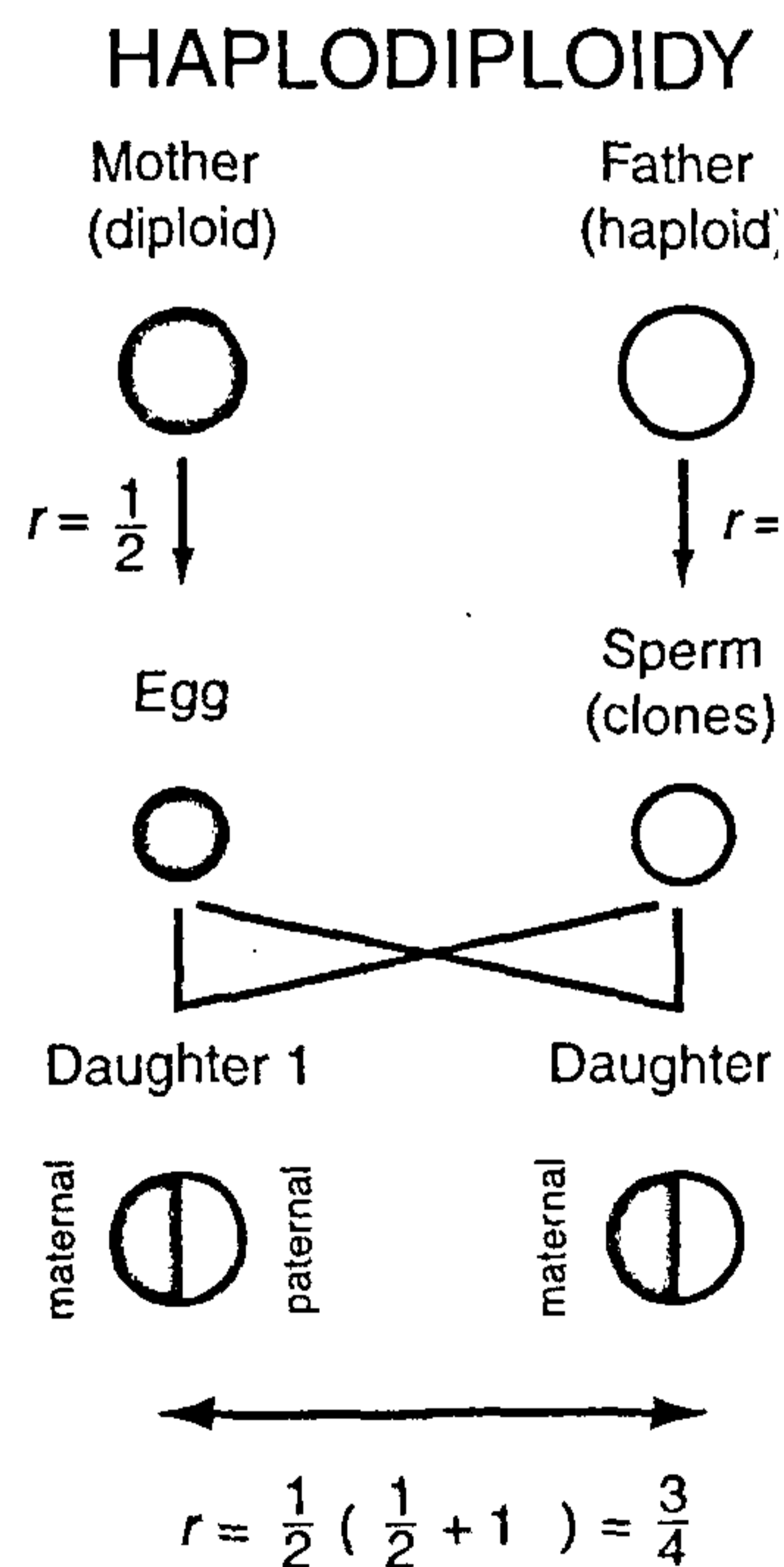
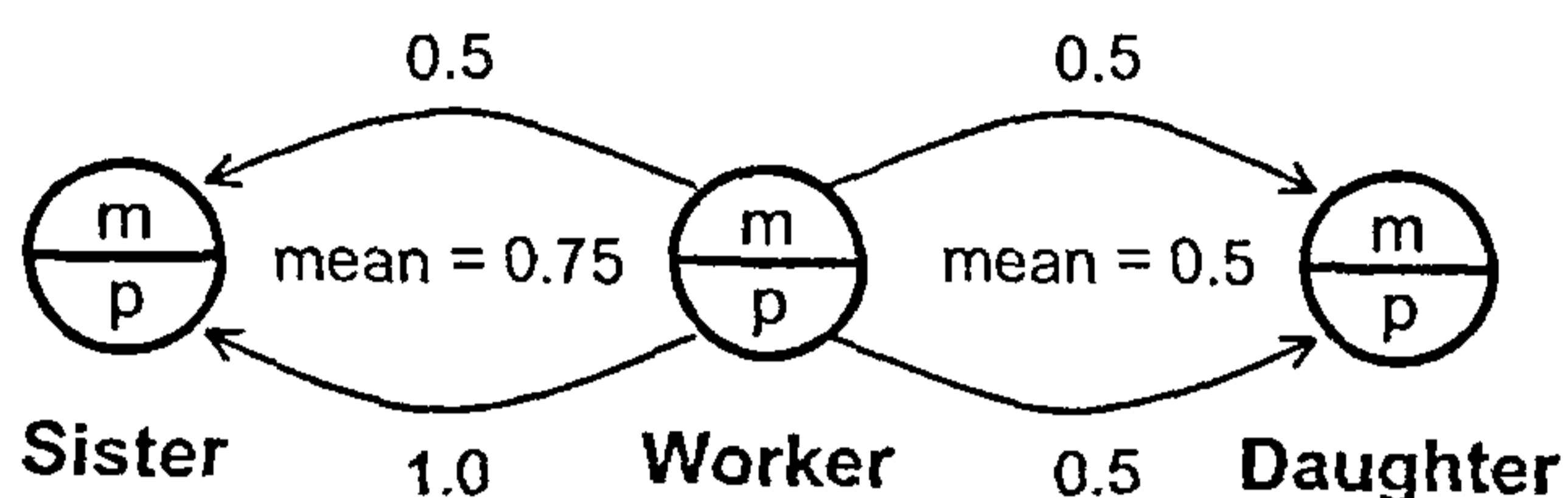

Figure 1. Genetic relatedness in haplodiploidy (see text for details).

Box 1. Implications of genomic imprinting I (after Haig¹¹)

Intra-genomic conflict between maternal and paternal genes over selfishness versus altruism.

Hamilton's haplodiploidy hypothesis showing preference for sisters over daughters was based on average relatedness.

Hymenopteran colony with singly mated queen

Average : Sisters > Daughters (1.5:1)
 Maternal genes : Sisters = Daughters
 Paternal genes : Sisters > Daughters (2:1)

- Mild selection for rearing sisters instead of daughters (= social evolution)
- No social evolution if maternal genes are in control
- Rapid social evolution if paternal genes are in control

Box 2. Implications of genomic imprinting II (after Haig¹¹)

Intra-genomic conflict between maternal and paternal genes over sex investment ratio.

Trivers and Hare's prediction that workers prefer a 3:1 investment in their sisters and brothers was based on average relatedness.

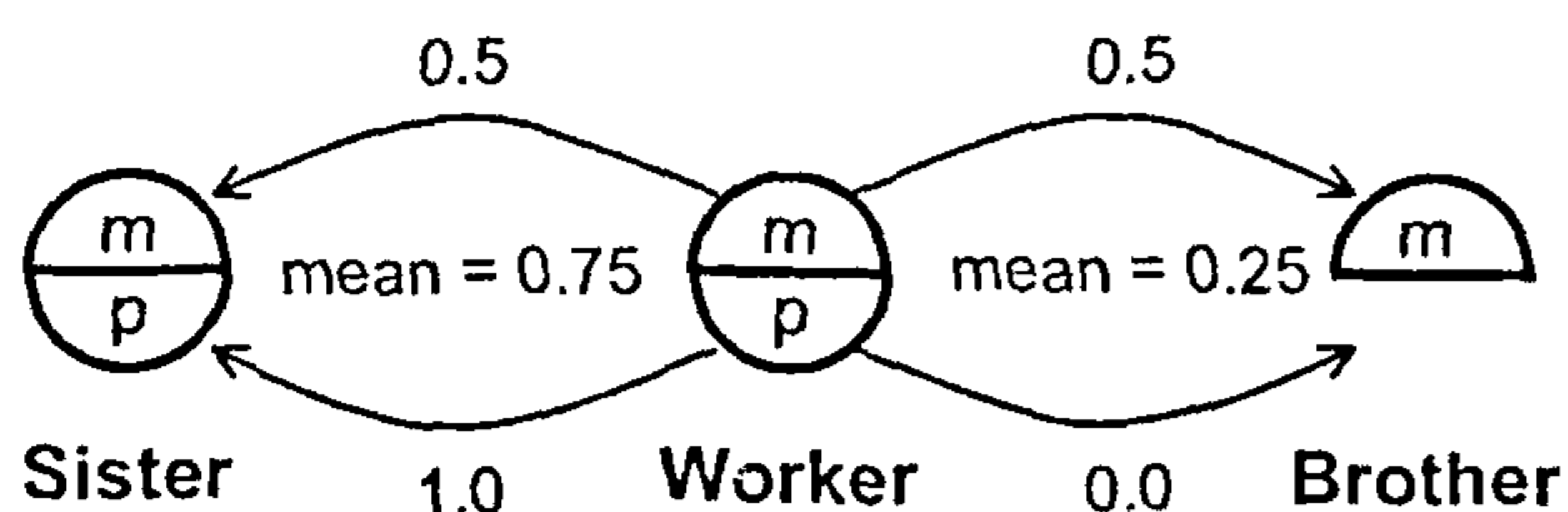
Hymenopteran colony with singly mated queen

Average : Sister : Brother :: 3:1
 Maternal genes : Sister : Brother :: 1:1
 Paternal genes : Sister : Brother :: 1:0

- Some queen-worker conflict if mean relatedness matters (as queen prefers 1:1)
- No queen-worker conflict if maternal genes are in control
- Intense queen-worker conflict if paternal genes are in control

that either workers should prefer their own sons over their brothers or, if they are forced to rear their sisters and brothers, they should prefer to invest in their sisters and brothers in the ratio 3:1 (0.75:0.25). A particularly fascinating

aspect of this prediction is that the workers' preferred ratio of investment (3:1) is in conflict with the queen's preferred ratio of investment of 1:1 in her daughters and sons. Hamilton's prediction and the prediction of Trivers

and Hare have since become the cornerstones of sociobiology and both have engendered an enormous body of theoretical and empirical work.

Both these sets of predictions were however based on the assumption that maternal and paternal genes in the bodies of the worker behave identically. Thus Hamilton as well as Trivers and Hare computed relatedness values (0.75, 0.5 and 0.25, discussed above) by taking the average values for maternal and paternal genes. But if the relatedness values are computed separately for the maternal and paternal genes, they turn out to be quite different and so do the predictions. For example, from the point of view of the maternal genes in a workers' body, sisters are as valuable as daughters, so that altruistic rearing of sisters should be favoured no more than selfish rearing of daughters (in both case, $r = 0.5$). From the point of view of the paternal genes on the other hand, sisters are twice as valuable as daughters so that altruistic rearing of sisters should be even more strongly favoured than selfish rearing of daughters (Box 1). A similar situation occurs with the predicted sex investment ratios. From the point of view of the maternal genes in a workers' body, sisters are as valuable as brothers so that a 1:1 sex investment ratio is favoured and thus there should be no conflict between queens and workers over sex investment. From the point of view of the workers' paternal genes however, all the paternal genes are expected to be found in sisters while none are expected to be found in her brothers. Hence paternal genes should favour all investment in sisters and none in brothers. Therefore queen-worker conflict should now be even more severe than what was predicted by a computation of average relatedness for maternal and paternal genes (Box 2).

As Haig¹⁵ readily admits, whether a major reappraisal of sociobiological theory is required will depend on how common genomic imprinting turns out to be in social insects. It is in this context that recent evidence for the role of genomic imprinting in sex determination in a parasitic wasp assumes significance. The wasp in question is *Nasonia vitripennis* and the study under consideration is by S. L. Dobson and M. A. Tanouye¹⁶ of the University of California

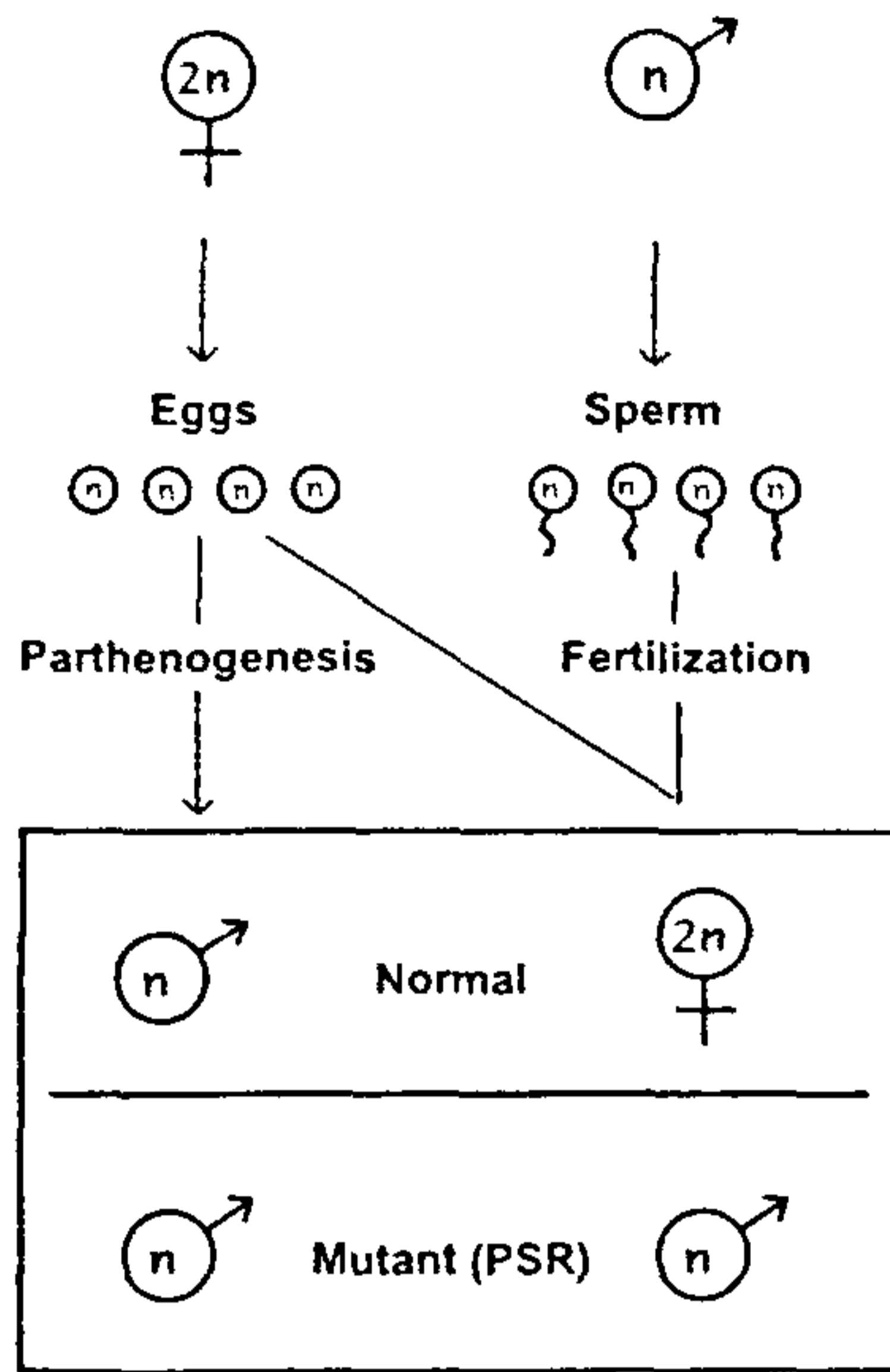

Figure 2. Life cycle of normal and PSR strains of *Nasonia vitripennis* (after Werren *et al.*¹⁷) (see text for details).

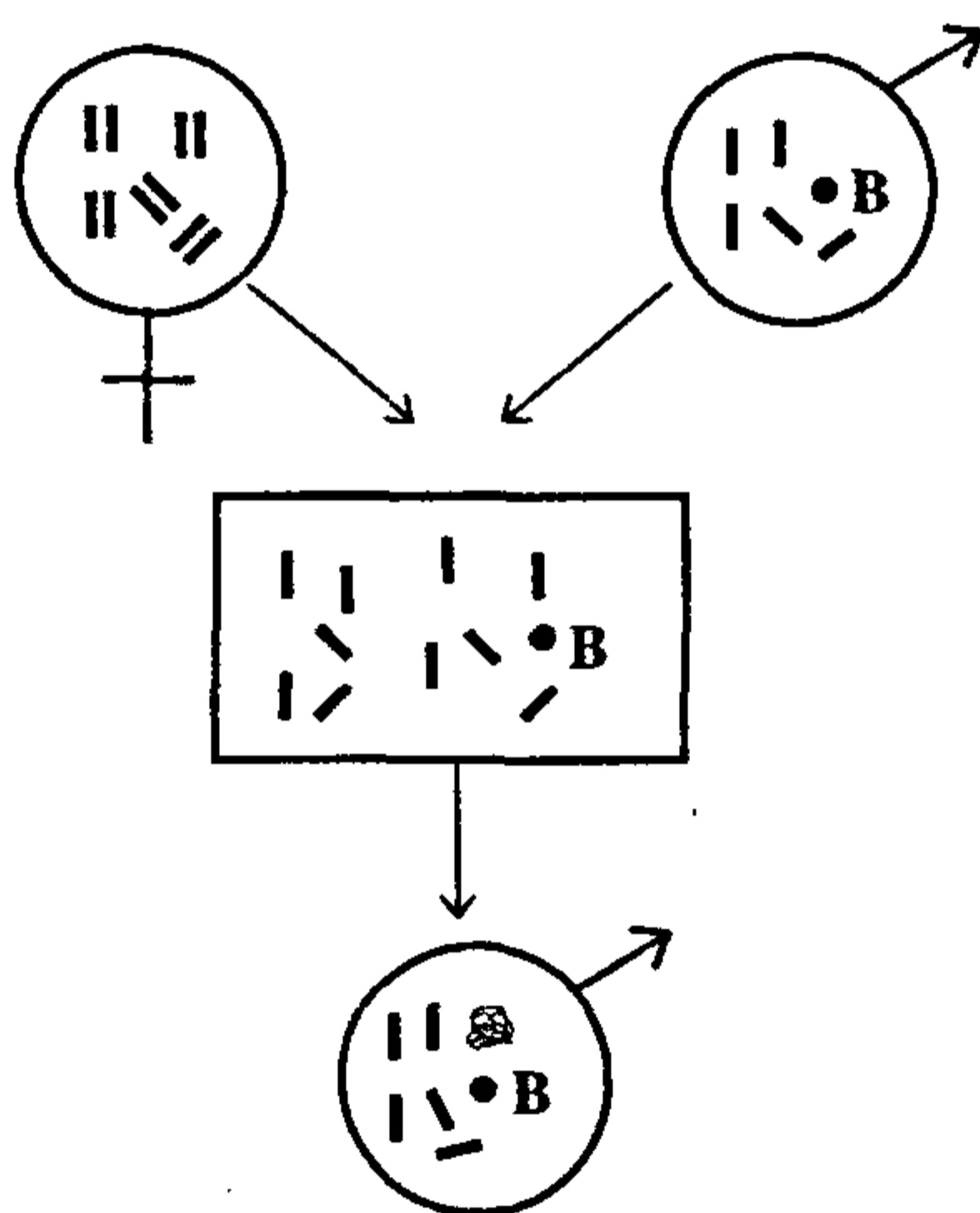

Figure 3. The mechanism of action of PSR in converting fertilized eggs into males (after Nur *et al.*¹⁸) (see text for details).

at Berkeley. *Nasonia vitripennis* is a parasitoid wasp that is distributed throughout the world. Female wasps lay eggs in the pupae of flies that breed in carcasses and in bird nests. Like all Hymenoptera, *N. vitripennis* is also haplodiploid and it is used as a favourite laboratory model system in a variety of genetic and evolutionary studies. As

it often happens with laboratory model systems, many unusual mutants that cannot usually survive in nature turn up in the laboratory cultures. Many strains of *N. vitripennis* are now known that distort the sex ratio of their offspring – variously called son killers and daughter killers! A rather famous one is called PSR, for paternally transmitted sex ratio factor¹⁷. Unlike the wild type strains, eggs fertilized by PSR males also develop into haploid males but these males do inherit the PSR factor (Figure 2). It turns out that PSR is a small, aberrant, unpaired chromosome (such chromosomes are called *B* chromosomes) that enters the egg along with the paternal chromosomes. Having done so it brings about the heterochromatinization and hence the loss of all paternal chromosomes¹⁸. This leaves the zygote only with the maternal chromosomes and the PSR itself (Figure 3). Not surprisingly, such zygotes develop into haploid, PSR containing males. PSR has thus been dubbed the most selfish genetic element known¹⁸ (see also Gadagkar¹⁹). It uses the male to reach the zygote and having done so it destroys its co-travellers (the paternal chromosomes) in order to ensure its future survival. PSR cannot survive unless it converts the diploid zygote that would normally develop into a female, into a male because PSR cannot transmit through a female body. PSR can only survive in a male body and since male hymenopterans normally have no sons it has no choice but to convert potential daughters into sons.

The aim of the Dobson and Tanouye¹⁶ study was to understand the mechanism of sex determination in the Hymenoptera. Even though we know that unfertilized eggs develop into males and fertilized eggs develop into females, the mechanism by which sex is determined is far from clear. The observation that unfertilized eggs develop into males and fertilized eggs develop into female is consistent with a variety of mechanisms – indeed there have been a variety of models proposed for sex determination in the Hymenoptera.

1. *Fertilization sex determination (FSD)*: According to this model, the very act of fertilization causes the egg to develop into a female, quite independent of the paternal genes that fertilization may bring with it²⁰.

2. *Single locus complementary sex determination (SCSD)*: A single sex determining locus is postulated and individual homozygous or hemizygous (as all haploid individuals are) are expected to develop into males while those heterozygous are expected to develop into females. Because the sex determining locus is believed to be highly polymorphic, diploid homozygotes are expected to be rare and the usual way to get males is therefore by the development of unfertilized (hemizygous) eggs. As predicted by the model, diploid, homozygous males can be produced by inbreeding²¹.

3. *Multiple loci complementary sex determination (MCSD)*: Because the prediction of SCSD do not always fit the empirical data, multiple sex determination loci have been postulated for some species. The prediction is that individuals homozygous or hemizygous at all of these loci will develop into males while those heterozygous for any one of these loci will develop into females^{22,23}.

4. *Genic balance sex determination (GBSD)*: According to this model, sex is determined by a balance between male determining genes (*M*) and female determining genes (*F*). Because *M* is postulated to be more powerful than *F*, haploid eggs with one set of *M* and *F* each develop into males ($M > F$). However fertilized eggs will have $2M$ and $2F$. The *M* genes are not expected to be additive in their effects while the *F* genes are expected to be additive. Thus $2F > M > F$, so that fertilized eggs develop into females²⁴.

5. *Maternal effect sex determination (MESD)*: This model proposes that sex is determined by the ratio of nuclear and cytoplasmic factors. Haploid eggs, having one set of nuclear and cytoplasmic factors each, develop into males. Fertilized eggs, with one set of cytoplasmic factor and two sets of nuclear factors (one set received from the father), develop into females^{25,26}.

6. *Genomic imprinting sex determination (GISD)*: This model proposes that genes in the mother are so imprinted that they can only direct male development. However genes in the father are so imprinted that they can

Table 1. Sex determination in *Nasonia vitripennis* (after Haig¹⁵, and Dobson and Tanouye¹⁶)

	Haploid eggs			Diploid eggs		
	Maternal chromosomes	Paternal chromosomes	Sex	Maternal chromosomes	Paternal chromosomes	Sex
Unfertilized	One set	Nil	Male	Two sets	Nil	Male
Fertilized by wild type male	One set	One set	Female	Two sets	One set	Female
Fertilized by PSR male	One set	Only PSR factor	Male	Two sets	Only PSR factor	Male

direct female development despite the presence of the maternal chromosomes. Only fertilized eggs contain genes with the paternal imprint and thus they develop into females^{27,28}.

It is fair to say that there is no satisfactory empirical support for any of these models. Genomic imprinting sex determination is the most recent proposal and the study of Dobson and Tanouye¹⁶ makes it possible to exclude all the previous five models and support only GIST, for *N. vitripennis*. Several other features of *N. vitripennis* permitted Dobson and Tanouye to design experiments that are not usually possible with other organisms. I have already described the PSR factor. By appropriate manipulations, one can also produce triploid females (with three sets of chromosomes) and diploid males. The triploid females produce haploid as well as diploid eggs and the diploid males produce diploid sperm! The basic experimental design of Dobson and Tanouye involved fertilizing haploid and diploid eggs with haploid and diploid sperm, with and without the PSR factor. With the help of three recessive eye colour markers they were able to assess whether the proportions of progeny of each sex and eye colour were as expected by different models for sex determination. Their most important result can be stated simply. When diploid eggs were fertilized by PSR containing sperm, the paternal chromosomes were lost as expected, leaving an embryo with two sets of maternal chromosomes and the PSR factor. All previous models of sex determination predict that these fertilized, diploid embryos should develop into females. They are fertilized (satisfying FSD), they are diploid and heterozygous (satisfying SCSD and MCSD) and diploid (satisfying GBSD and MESD). Only the genomic model predicts that these embryos should de-

velop into males. And Dobson and Tanouye found that these embryos indeed developed into males (Table 1). As they admit, the possibility that PSR itself has male determining genes cannot be completely ruled out. However previous deletion analysis has failed to separate the ability of PSR to convert fertilized embryos into males and its property of eliminating paternal chromosomes²⁹. Thus it appears that elimination of paternal chromosomes is the mechanism by which PSR converts fertilized eggs into males. Although these eggs are fertilized and have a heterozygous, diploid chromosome composition, they only have maternally imprinted chromosomes. Lack of paternally imprinted chromosomes can thus be thought of the reason why they do not develop into females.

Needless to say, this evidence in favour of imprinting as a mechanism of sex determination in a Hymenopteran insect (or indeed in favour of any mechanism of sex determination!) is of great interest to all of us who have long been uncomfortable with our inability to come to grips with, as fundamental a problem as sex determination, in the organisms we study. Even more importantly, this evidence in favour of genomic imprinting comes as a reminder that a reappraisal of sociobiological theory may be required sooner or later. The best evidence for the role of genomic imprinting followed by differential expression of maternal and paternal genes, comes from mammalian systems^{30,31}. And it is in mammalian systems that the role of genomic imprinting is also being vigorously investigated in another area of sociobiological theory namely, inter-sexual conflict^{32,33}. When females mate with a different male each time they produce an offspring, male-female conflict continues in the bodies of their offspring. While the mother would like to distrib-

ute her resources nearly equally between her present and future offspring, the father would like the present offspring (which is his) to get as much of the maternal resources as possible, unmindful of the health of future offspring (who are not likely to be his). It has therefore been postulated that genes which may be involved in modulating the resource drawing abilities of offspring become differentially imprinted, to express the conflicting interests of the mother and the father. The most famous example is the case, or as Haig and Graham³⁴ call it, 'the strange case of the insulin-like growth factor II'. Insulin-like growth factor II (IGF II) is a polypeptide that helps rapid embryonic growth in mice. As expected from the theory of genomic imprinting mentioned above, the paternal copy of IGF II is well transcribed while the maternal copy is almost silent³⁵. This is consistent with the idea that the father's genes are attempting to enhance the resource drawing ability of the offspring while the mother's genes are not particularly encouraging this. The 'strange' case concerns the type 2 receptor for IGF II. While the type 1 receptor appears to behave normally, the type 2 receptor is unusual. First, it is transcribed mainly from the maternal genome and not from the paternal genome³⁶. Secondly, the type 2 receptor is in other contexts a cation-independent mannose-6-phosphate receptor which binds mannose-6-phosphate residues on lysosomal enzymes and transports them into lysosomes. Haig and Graham have theorized that the receptor which mediates the normal function of IGF II is the type 1 receptor and that the type 2 receptor has been hijacked by the mother to act as a sink for excess IGF II and thus limit embryonic growth³⁴. That the type 2 receptor gene is subject to imprinting of the opposite kind as compared to IGF II is consistent with this idea. Thus the father's genes appear to

make plenty of growth factor and promote embryonic growth while the mother's genes find a way of eating up this growth factor and limit embryonic growth.

There has been some effort at more formal population genetic modeling of these phenomena which, by and large, lend support to the ideas of Haig and his colleagues³⁷⁻³⁹. Nevertheless, it must be recognized that a great deal of all of this speculation remains to be tested, either by modeling or by experiments. But it is today's speculation that will guide tomorrow's research.

1. Peterson, K. and Sapienza, C., *Annu. Rev. Genet.*, 1993, **27**, 7-31.
2. Chandra, H. S. and Brown, S. W., *Nature*, 1975, **253**, 165-168.
3. Chandra, H. S. and Nanjundiah, V., *Development*, 1990, supplement, 47-53.
4. Ohlsson, R. (ed.), *Genomic Imprinting: An Interdisciplinary Approach*, Springer-Verlag, Berlin, 1999.
5. Ohlsson, R., Hall, K. and Ritzen, M. (eds), *Genomic Imprinting: Causes and Consequences*, Cambridge University Press, Cambridge, 1995.
6. Reik, W. and Surani, A. (eds), *Genomic Imprinting: Frontiers in Molecular Biology*, Oxford University Press, Oxford, 1997.
7. Gold, J. D. and Pedersen, R. A., *Curr. Top. Dev. Biol.*, 1994, **29**, 227-280.
8. Jaenisch, R., *Trends Genet.*, 1997, **13**, 323-329.
9. Kass, S. U. and Wolffe, A. P., in *Epigenetics (Novartis Foundation Symposium 214)*, (eds Chadwick, D. J. and Cardew, G.), John Wiley & Sons, New York, 1998, pp. 22-45.
10. Reik, W. and Walter, J., *Curr. Opin. Genet. Dev.*, 1998, **8**, 154-164.
11. Haig, D., *J. Theor. Biol.*, 1992, **156**, 401-403.
12. Hamilton, W. D., *J. Theor. Biol.*, 1964, **7**, 1-16.
13. Hamilton, W. D., *J. Theor. Biol.*, 1964, **7**, 17-52.
14. Trivers, R. L. and Hare, H., *Science*, 1976, **191**, 249-263.
15. Haig, D., *Trends Ecol. Evol.*, 1998, **13**, 380-381.
16. Dobson, S. L. and Tanouye, M. A., *Genetics*, 1998, **149**, 233-242.
17. Werren, J. H., Nur, U. and Eickbush, D., *Nature*, 1987, **327**, 75-76.
18. Nur, U., Werren, J. H., Eickbush, D. G., Burke, W. D. and Eickbush, T. H., *Science*, 1988, **240**, 512-514.
19. Gadagkar, R., *Survival Strategies - Cooperation and Conflict in Animal Societies*, Harvard University Press, Cambridge, Massachusetts, and Universities Press, Hyderabad, 1997.
20. Whiting, P. W., *Genetics*, 1960, **45**, 949-970.
21. Whiting, P. W., *Genetics*, 1943, **28**, 365-382.
22. Crozier, R. H., *Am. Nat.*, 1971, **105**, 399-412.
23. Snell, G. D., *Proc. Natl. Acad. Sci. USA*, 1935, **21**, 446-453.
24. Da Cunha, A. B. and Kerr, W. E., *Forma Functio*, 1957, **1**, 33-36.
25. Crozier, R. H., *Annu. Rev. Entomol.*, 1977, **22**, 263-288.
26. Cook, J. M., *Heredity*, 1993, **71**, 421-435.
27. Poirié, M., Périquet, G. and Beukeboom, L., *Dev. Biol.*, 1992, **3**, 357-361.
28. Beukeboom, L. W., *BioEssays*, 1995, **17**, 813-817.
29. Beukeboom, L. W. and Werren, J. H., *Genetics*, 1993, **133**, 637-648.
30. Barlow, D. P., *Science*, 1995, **270**, 1610-1613.
31. Bartolomei, M. S. and Tilghman, S. M., *Annu. Rev. Genet.*, 1997, **31**, 493-525.
32. Haig, D. and Westoby, M., *Am. Nat.*, 1989, **134**, 147-155.
33. Haig, D., *Proc. R. Soc. London B.*, 1997, **264**, 1657-1662.
34. Haig, D. and Graham, C., *Cell*, 1991, **64**, 1045-1046.
35. DeChiara, T. M., Robertson, E. J. and Efstratiadis, A., *Cell*, 1991, **64**, 849-859.
36. Barlow, D. P., Stöger, R., Herrmann, B. G., Saito, K. and Schweifer, N., *Nature*, 1991, **349**, 84-87.
37. Mochizuki, A., Takeda, Y. and Iwasa, Y., *Genetics*, 1996, **144**, 1283-1295.
38. Spencer, H. G., Feldman, M. W. and Clark, A. G., *Genetics*, 1998, **148**, 893-904.
39. Spencer, H. G., Clark, A. G. and Feldman, M. W., *Trends Ecol. Evol.*, 1999, **14**, 197-201.

Raghavendra Gadagkar is in the Centre for Ecological Sciences, Indian Institute of Science, Bangalore 560 012, India; and Evolutionary and Organismal Biology Unit, Jawaharlal Nehru Centre for Advanced Scientific Research, Jakkur P.O., Bangalore 560 064, India. (e-mail: ragh@ces.iisc.ernet.in; internet: http://ces.iisc.ernet.in/hpg/ragh)