

through rotation at intervals. We should recruit expert-help from outside, an idea vehemently opposed by the 'mandarins' of Indian science. At present, there is no independent audit of individual or mission-oriented research projects. Like in finance and accounts, the 'spender' cannot be the 'auditor'.

UGC and all Government agencies and NGOs involved in science and technology development in India should support this 'experiment' because it is revolutionary and original. It is a direct attempt to replant the cured soil of higher education in science with an epigenetically modified and better-yielding variety. Only after success in such efforts would we deserve the status of the third largest work-force in science and technology. Indeed, it is worth rerouting this work-force and even decreasing it because the quality, rather than quantity, is relevant to the process of nation building at this point. Even if the part dealing with the +3 level is implemented, the scenario for life sciences will change dramatically in India. A 5-year M Sc programme is not

another band-wagon to attract 'good' students. It must transcend geo-political considerations. Indian teachers are parochial and hate mobility. Then, let students move, as they do, to the training site. The psychological 'fix' by a 5-year M Sc⁶ will automatically curtail the use of students as the 'manual labour' for the peers practising science by 'proxy'.

1. Modak, S. P., in *Switzerland, as seen by others* (ed. Commission de coordination pour la présence de la Suisse a l'étranger), Der Altag/Scalo Verlag AG, Zurich, Switzerland, 1992, pp. 121-133.
2. Sitaramam, V., *Curr. Sci.*, 1991, **60**, 537-540.
3. Sitaramam, V. and Sauna, Z. E., *Curr. Sci.*, 1996, **70**, 335-340.
4. Indian Academy of Sciences, 1994, Acad. Papers no. 1, pp. 1-32.
5. Sitaramam, V., *Curr. Sci.*, 1995, **69**, 89-94.
6. Estimated cost: Rs. 4.5 crores for capital expenditure, Rs. 50 lakhs/year recurring, an intake of 40-50 students/year, and an endowment of Rs. 4 crores to cover salaries (1995-96 scales). Methods for aptitude tests are being studied.

ACKNOWLEDGEMENTS. I thank Dr V. Gowariker, Prof. M. N. Palsane, and Mr. Zuben Sauna of the University of Pune for critical discussions.

REVIEW ARTICLE

Progress towards malaria vaccine

V. S. Chauhan

International Centre for Genetic Engineering and Biotechnology, Aruna Asaf Ali Marg, New Delhi 110 067, India

Resurgence of malaria has reached alarming proportions. The situation has become worse because of the widespread resistance to anti-malarials. Thus malaria vaccine research has become an area of intense activity even though host-parasite interactions are not well understood. Several antigens from different stages of the life cycle of malaria parasite have been identified. It is now clear that both antibodies and cellular immune responses are involved in malaria immunity. At the

same time it is becoming clear that plasmodium has developed exquisite mechanism to evade the immune responses mounted by the host. All kinds of vaccine constructs, based on recombinant antigens, synthetic peptides, and direct use of DNA are being attempted and several of these are undergoing human trials. Results of these trials and other research works clearly indicate that malaria vaccine development is hugely complex and success may not come easily.

MALARIA continues to be a major cause of morbidity and mortality in the tropical and subtropical areas of the world where approximately 350 million malaria cases occur each year. More than two million children die of the disease annually. The overwhelming success of chloroquine as a drug and DDT as an insecticidal, introduced in 1960s resulted in an impression that malaria could be controlled to a large extent if not eradicated. Unfortunately, resistance of the human malaria parasite *Plasmodium falciparum* to anti-malarial drugs and to its mosquito vector to insecticides has led to an alarming situation and drugs-resistant strains of *P. falciparum* have spread throughout the tropics. Given the fact that

no new anti-malarial drugs or new insecticides superior to DDT are likely to be available in the near future, the disease situation is becoming hopeless.

Vaccine should be a useful addition to chemotherapy and the vector control program in malaria control. However, until recently there was no way to obtain sufficiently large amounts of antigenic material from the parasite. With the availability of *P. falciparum* in culture form, it has become possible to study the molecular basis of the parasite function. Identification and production of antigens involved in protective immunity by applying tools of modern biology has changed the direction of malaria research, particularly the vaccine development.

There are four species of human malaria: *P. falciparum*, responsible for practically all malaria deaths, *P. vivax*, also widespread and the cause of considerable morbidity, and the less prevalent species *P. ovale* and *P. malariae*. The parasite undergoes a complex life cycle. There are three major stages in the life cycle and each of the developmental stages is morphologically and antigenically distinct and there appear to be several antigenic molecules at each stage that could be potential vaccine targets.

Malaria vaccines against the three distinct developmental stages of the parasite are being developed^{1,2}. Vaccines against the pre-erythrocytic stages of malaria aim to eliminate infection by blocking sporozoites from entering hepatocytes or by destroying the infected hepatocytes. The second type of vaccine targeted against the blood stages of the parasite which would be expected to prevent the disease or significantly reduce the parasite load, and therefore the intensity of infection. The third type is aimed at the sexual stages of parasite and aims to limit transmission of the disease. An altogether different kind of vaccine, namely anti-disease vaccine, has also been proposed³. Such a vaccine would aim to neutralize factors responsible for the pathology associated with malaria infection. Keeping in view our own research in the malaria research group at ICGEB, the main focus of this review will be on sporozoite and blood stage based vaccines.

Despite tremendous progress in malaria research during the past twenty years which has led to a vast amount of information, the exact nature of malaria immunity and effector mechanisms involved remain ill understood. Malaria immunity is slow to acquire and is usually short-lived. Thus, children up to 5 years of age are most susceptible to severe clinical disease; adults show little parasitaemia and rare clinical disease. The highly polymorphic nature of malaria antigens within each parasite species and antigen structure are proposed to be the main reasons for the slow and transient nature of the acquired immunity. Further, the immunity is both species- and stage-specific. A person with immunity to *P. falciparum* may still be susceptible to *P. vivax* infection and vice versa. Similarly, immunity to the sporozoite stages may still leave an individual susceptible to the blood stage infection. It is often thought that a successful malaria vaccine will have components from several antigens belonging to the different stages of the parasite. However, non-availability of a suitable animal model for human malaria will remain a major hurdle in the development of malaria vaccines.

Is there a rationale for a malaria vaccine?

Given the complexity of the parasite's life cycle, complicated and ill-understood host-parasite interactions

and several mechanisms that are operative in favour of the parasite to evade immune responses, it does appear that development of an antiparasite vaccine will be a very difficult task, if not an impossible one. On the other hand, there are several reasons to believe that malaria vaccine will be developed in future. Some of these are:

1. Individuals living in malaria endemic areas do develop specific immunity that decreases the parasite's ability to survive in the human host and also decreases the clinical consequences of infection. However, in contrast to rapid and long-lasting immunity induced during viral infections, malaria immunity takes a long time to develop and is usually short lived in absence of continued exposure to infection. Clearly a successful malaria vaccine will have to be more effective at inducing immunity than the natural infection.

2. Transfer of immunoglobulin from individuals with acquired malaria immunity, to naive humans almost completely protected them from infection⁴.

3. Immunization with irradiated sporozoites induces a solid immune protection in animals^{5,6} and in humans⁷. However, only intravenous deposition of irradiated sporozoites, not a convenient route for general vaccination, provides optimum protection.

4. Significant levels of protection were observed in early trials when purified malarial antigens were used as immunogens^{8,9}. More recently, several trials with recombinant antigens have shown high levels of protection against challenge with blood stage parasites^{10,11}. This is encouraging for vaccine developments since only a few antigens, out of the numerous suggested have actually been tested in primates. It is very much possible that valuable vaccine antigens will be discovered and used as vaccine candidates.

Nature of malaria vaccines

Most successful vaccines have been based on attenuated or killed pathogens. Since human blood is needed for *P. falciparum* culture and *P. vivax* has not yielded to culture at all, the focus in malaria vaccine development is largely limited to well-defined molecules which can induce protective immune responses and now be easily produced by recombinant DNA techniques in various systems. While a recombinant hepatitis B vaccine is already in use in humans, several other recombinant vaccines are in the developmental stage.

The fact that immune response against short peptide can produce neutralizing antibodies against viral and other proteins, has opened way to the development of synthetic peptides as immunogens for vaccination¹². But short peptides are usually poor immunogens, and the carrier proteins that are traditionally used to enhance their immunogenicity have inherent problems associated

with their use¹³. Use of T cell determinants in place of carrier proteins is being investigated¹⁴⁻¹⁶.

Viral vectors including vaccinia and salmonella have been considered as vehicles for carrying the gene of a target antigen. More recently, direct DNA immunization has also been attempted in malaria vaccine development¹⁷. The main attraction of developing viral vectors or direct DNA immunization protocols is that it obviates the use of adjuvants which are necessarily needed in case of recombinant proteins and synthetic peptides.

Liver stage antigens

The early observation that immunization with irradiated sporozoites could protect rodents or humans against challenge with viable sporozoites provided the basis for much of the work on the sporozoite stage vaccine⁵⁻⁷. It is now clear that both humoral and cell-mediated immune functions contribute to the acquired immunity in man. In rodent model system also, antibodies to the circumsporozoite protein, CD⁴⁺ cells and CD⁸⁺ T cells have all been implicated in protection. Of the liver stage proteins, the circumsporozoite (CS) protein has primarily been the focus of most studies in both rodents and humans¹⁸.

The CS protein covers the whole surface membrane in mature salivary glands, of all malaria species sporozoites and is believed to be involved in the process of sporozoite's penetration into hepatocytes. All CS proteins have an immunodominant epitope in the middle region formed by tandem repeats of amino acids, which vary in sequence among different species of malaria parasites. It was observed that antibodies to the epitopes formed by the repeats mediate protection against sporozoite-induced malaria. This led to the first generation of subunit malaria vaccines to be tried in humans. Two candidate vaccines based on (Asn-Ala-Asn-Pro) repeats were developed. One of these was a recombinant polypeptide (R32tet32), containing thirty two *P. falciparum* CS repeat units, fused to a sequence of 32 amino acid residues from the plasmid vector. The other vaccine consisted of synthetic dodecapeptide, (Asn-Ala-Asn-Pro)₃, which represents the epitope recognized by antibodies in the sera of humans living in endemic areas, conjugated to tetanus toxoid. However, both the constructs were poorly immunogenic in humans, when administered in alum^{11,19}. Limited protection which correlated with the levels of anti-repeat antibodies was observed but by and large these trials were considered unsuccessful. Similarly in another human trial, poor immunogenicity was again observed when a recombinant CS protein of *P. vivax* was administered in alum²⁰. It was soon realized that a successful anti-sporozoite vaccine will have to induce high antibody levels to the repeat sequence with the appropriate specificity. It is

now clear some parasite antigens like the CS protein are poorly immunogenic because the helper T-cell epitopes lie mostly in the polymorphic region of the protein. A vaccine dependent on a foreign carrier protein to provide T-cell help may provide high primary antibody response, but will not respond to subsequent parasite challenge, and therefore will not be effective unless administered repeatedly.

The target for cellular immunity can be any antigen, surface or internal of the parasite, containing one or more T-cell epitopes. Sensitized T-cells may secrete γ -interferon or other lymphokines including tumour necrosis factor or oxygen species which are known to kill parasites²¹. Further, cytotoxic T-cells (CD⁸⁺), in addition to activating the non-specific effector functions, may also recognize specific epitopes on parasite-infected hepatocytes and kill them. While T cell responses to CS protein have been studied in some detail, recently, two other liver stage antigens namely, the sporozoite surface antigen 2. (SSP-2) and the liver stage antigen 1 (LSA-1) have been characterized and their immune responses in humans and in animals are being evaluated, in order to develop these antigens as possible vaccine candidates^{22,23}.

Asexual blood stage antigens

Antibody response to the asexual blood stages of malaria parasites is extremely diverse. A very large number of polypeptides are recognized by antibodies in the serum of malaria-infected individuals. Selection of suitable candidate proteins from a very large number of antigens is itself a major difficulty in the development of a blood stage malaria vaccine (Table 1). Since the titre of antibodies to the blood stage antigens does not correlate with protection, it is quite possible that most antigens do not produce protective responses. The immediate goal, therefore, is to identify the antigens capable of inducing protective immune responses.

Non-availability of a suitable animal model is another major block in the way of malaria vaccine development. Although a vaccine target antigen for *P. falciparum* can be tested in Aotus or Saimiri monkeys, the infection in monkeys takes somewhat different course than the human disease. Moreover these monkeys are not easily available. For these reasons, indirect criteria such as location and the possible function of the antigens are often used in choosing a possible protective antigen. Some of the major vaccine target antigens from the blood stages of the malaria parasites are briefly described below.

Most protection studies with recombinant polypeptides fragments or chemically synthesized hybrid peptides have focused on a relatively small number of antigens. Major surface protein 1 (MSP-1) was one of

the first antigens identified as a potential vaccine candidate. It contains variable and highly conserved regions and is synthesized as a large protein, anchored to the merozoite surface and undergoes processing in two steps. Recombinant fragments representing the MSP-1 conserved regions were found to induce partial protection in Saimiri monkeys²⁴. That immunogenicity of peptide fragment can be highly enhanced by covalently attaching it to suitable T helper cell epitopes was shown in case of a conserved MSP-1 fragment, and higher levels of protection were observed in monkeys with such a construct²⁵. A significant result of these studies was the speculation that the protection was at least partially T-cell mediated. We have also characterized B and T-cell epitopes in the conserved regions of MSP-1 and have used these epitopes in the design of multiple epitope peptides²⁶. The C-terminal 19 kDa fragment, highly rich in cysteine residues, which are found conserved in several species of *Plasmodium*, appears to be crucially involved in merozoite invasion of erythrocytes and is carried into cells by invading merozoites²⁷. Phase one and phase two clinical trials using this fragment are being planned in the USA.

The second merozoite surface protein (MSP-2) is a 45 kDa protein located on the surface of the merozoite. The molecule contains a variable central repeat region, but the N and C terminal regions are highly conserved. Synthetic peptides from these conserved regions of Pf MSP-2, conjugated to a carrier protein, provided significant protection against *P. chabaudi* challenge in mice²⁸. Phase I trials with a combination of MSA-2 and the CSP protein have been conducted in Australia. Apical membrane antigen (AMA-1) is another protein that is highly conserved in all species of plasmodium analysed so far²⁹. Monoclonal antibodies against this antigen inhibit merozoite invasion of red cells and currently this antigen is undergoing human trials as a vaccine candidate. Genes for blood stage proteins like the acid base rich antigen (ABRA), the ring-infected erythrocyte surface antigen (RESA), the serine rich antigen (SERA), erythrocyte binding antigen (EBA-175) and several other malaria antigens (Table 1) have been cloned and sequenced³⁰. These antigens are at different stages of development for their potential as vaccine target antigens^{30,31}. Immunization studies with these antigens, produced by recombinant methods have resulted in a wealth of information which ironically reveal that malaria immunity might be more complex than thought earlier. As a result of this it is now believed that an approach of combining several conserved antigens in a cocktail vaccine might be more successful in addition to providing a means to reduce the risk of the selection of vaccine resistant forms of the parasite. An attenuated live vaccinia virus-based vaccine consisting of seven candidate antigens from the different life stages of the parasite, known as NYVAC-7, is being tested in humans for safety and immunogenicity in the USA.

Synthetic peptides as malaria vaccines

An alternative to the use of full length recombinant or native antigens is to identify the peptide epitopes on immunogens which induce a protective response and to use synthetic versions of the peptides in the production of vaccines. This approach seems particularly suited for parasitic diseases where it is increasingly being realized that some crucial epitopes of vaccine target antigens remain cryptic during immunization with the native antigens.

A synthetic peptide-based polymer, termed as SPf 66, developed by M. E. Patarroyo in Colombia, has undergone extensive human trials in several locations in Latin America and more recently in Africa and South East Asia³²⁻³⁵. The basic unit of SPf 66 as a hybrid peptide represents epitopes from CS protein, MSP-1 and two other sequences from yet-to-be-characterized 35 kDa and 55 kDa proteins from the blood stages of the parasite^{36,37}. Following the protection experiments in monkeys, the first human trials with SPf 66 were conducted in South America where high levels of protection were reported³³. These and subsequent results from a field study conducted in Tanzania confirmed that the vaccine was safe, induced anti-SPf66 antibodies and was able to provide up to 30% protection in the immunized children³⁴. However, more recent and carefully-designed studies conducted in The Gambia and in Thailand have shown³⁵ that SPf 66 could not provide any protection at all. It is now more or less accepted that this vaccine is not protective in areas of high malaria endemicity and that further efficacy trials are not warranted³⁵. This has been a major setback to malaria vaccine development and the question as to why SPf66 has failed after initial promise of partial protection does become a relevant one, in particular with respect to field trials involving future vaccine candidates.

The development of SPf66 has been full of controversies, ranging from scientific criticism to the issue of attitudes towards research carried out in a developing country. M. E. Patarroyo published in 1988 his findings that SPf66 was partially protective against *P. falciparum* infection in both Aotus monkeys and humans^{36,37} and since then insisted that SPf66 is a viable malaria vaccine. His enthusiasm has never been shared with vigour by other scientists³⁸ which was partly due to the fact that two independent trials with SPf66 in monkeys failed completely^{39,40}. The protection observed in large field trials in Latin America was also subjected to debates on the basis of inadequate epidemiological design of these trials and claims that SPf66 could also protect against *P. vivax* infection; the latter certainly appeared implausible. These arguments were certainly rational and intellectually justifiable. However, it should be pointed out that the same arguments could equally well apply to several clinical and field trials, including some peptide

based malaria vaccines, performed by scientific institutions in the developing world who were critical of Patarroyo's claims. Looking back, however, it does seem that the simple approach of attempting to produce a minimalist mimic of the malaria parasite was ambitious, just as it must be said once again, were the human trials conducted in the USA with the synthetic constructs based on repeat structures of the CS protein. Doubts about the design of the earlier field trials with SPf66 were, however, removed in the later trials done in collaboration with WHO/TDR in Tanzania. But the most puzzling observation in all these human trial studies^{33,34} was the fact that while SPf66 produced antibodies upon immunization, it had no correlation with the observed protection. Since the vaccine was not designed to induce any cellular responses, it remained unclear how the observed protection^{33,34} was being achieved. Perhaps some unknown protective mechanisms were involved. In the end, however, the inability of other workers to reproduce some of the key results described for SPf66, along with the results of the recent human trials in The Gambia and Thailand does seem to suggest that there is little chance that it will be used as a vaccine against malaria. Be that as it may, the development of SPf66 has certainly established that a chemically synthesized peptide construct can be a safe immunogen in humans, and has opened way for the development of other peptide-based vaccines.

Malaria research at ICGEB

Some of the major malaria antigens have within their structures regions that are highly conserved, not only within the different strains of the parasite but also among different species of malaria parasite. It has been argued that it is most meaningful to base vaccine constructs on the regions that have remained conserved under immunological pressure; such sequences are more likely to represent functional domains of the parasite surface proteins. My research group at ICGEB has followed this approach to develop synthetic peptide immunogens as malaria vaccine candidates, to be initially tested in animals.

A special feature of most malaria proteins is the presence of immunodominant repeat peptide structures⁴¹. There is also extensive antigenic cross-reactivity reported in malaria and these factors appear to be involved in immune evasion mechanisms developed by the parasite⁴². To probe if the repeat structures contribute to the observed cross-reactivity among the known antigen of *P. falciparum*, we synthesized peptides based on repeat structures from different antigens of *P. falciparum* and were able to show in a specific manner that the humoral immune responses to these peptides are highly cross-reactive⁴³. Circular dichroism studies on these peptides revealed that these peptides tend to adopt helical structure in solution. However, it is not clear if the

preference of repeat peptide structures for a given secondary structure alone is responsible for the observed immunological cross-reactivity³⁶. Interestingly, we found that the peptides based on *P. vivax* repeat structures did not show any significant cross-reactivity with the *P. falciparum*-based peptides (unpublished work, Chauhan *et al.*). It is now firmly believed that highly immunodominant repeat structures are utilized by the parasite to evade immune responses mounted by the host. It is also being suggested that epitopes crucial for the parasite survival may remain mostly hidden, and although functionally relevant, they may not be as accessible to the immune system of the host as the structurally dominant repeat structures. Delineation of such conserved, perhaps cryptic, epitopes may be necessary to the design of a peptide-based malaria vaccine.

The epitopes recognized on a protein may be linear or spatial: B-cell epitopes, involved in the recognition of antigens by antibody, may be either linear or discontinuous, but the T-cell epitopes, involved in cell-mediated immunity and T helper activities, are invariably linear. Peptides themselves are poor immunogens and usually need to be conjugated to a suitable protein to obtain an immune response. We were able to show that immunogenicity of a B epitope from Pf MSP-1 could be enhanced by linking it covalently with a T-cell epitope sequence from the CS protein or tetanus toxoid¹⁶. There is increasing evidence that highly enhanced and specific immune responses can be obtained by combining B-cell epitopes with Th epitopes although

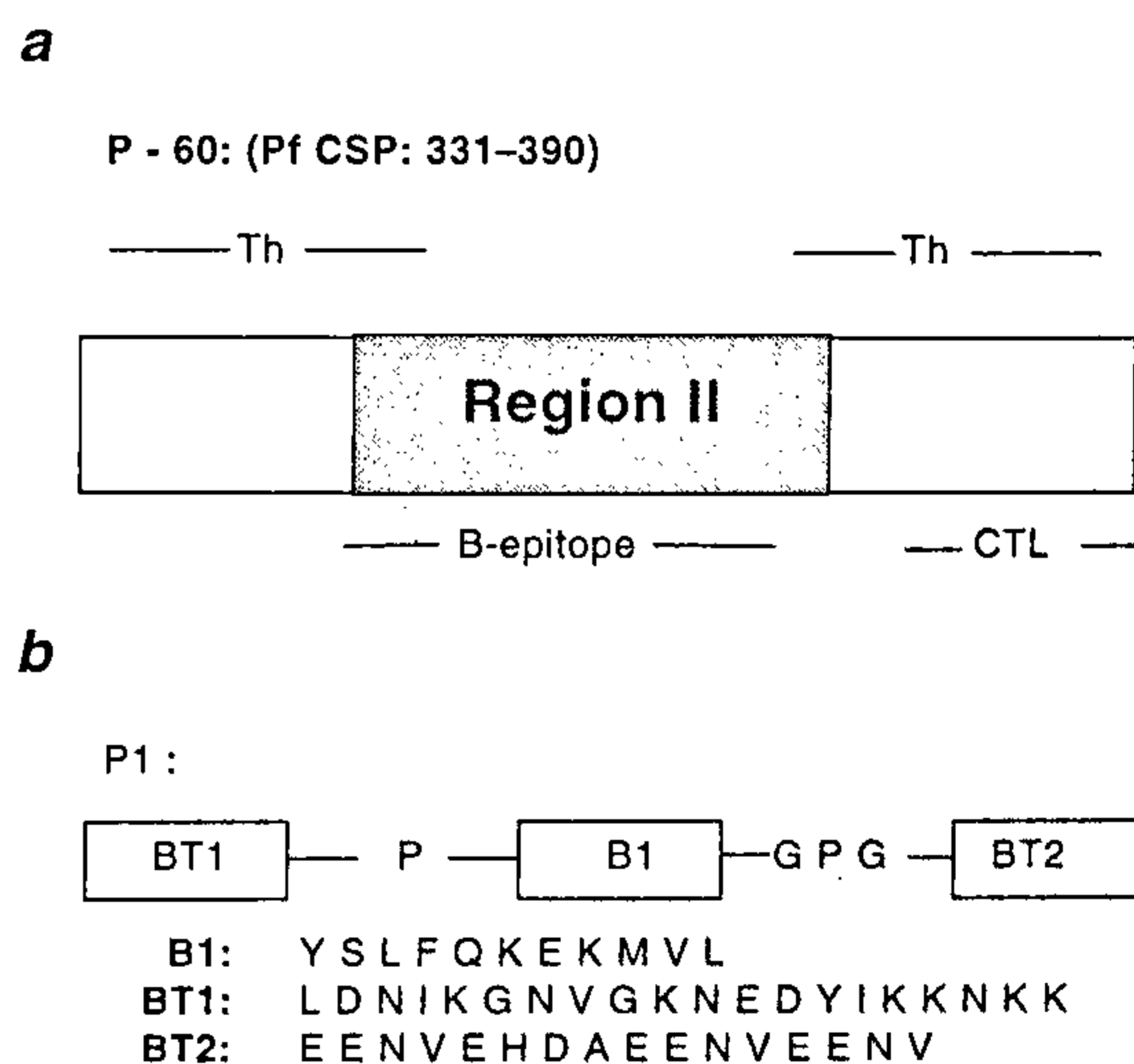

Figure 1 a, b. Schematic representation of P60 and P1 indicating the location of different epitopes. **a**, At the N-terminus of P60 is a Th epitope (amino acid residue no. 331-349 of the CSP) overlapping a B epitope in region II (residues 346-363 of the CSP), followed by another Th epitope (362-381) and an overlapping CTL epitope (368-390). **b**, BT1 and B1 are peptide sequences from MSP-1 whereas BT2 is a peptide sequence from RESA in a hybrid peptide P1.

Table 1. Asexual stages vaccine target antigens

Antigens	Approx. size	Location
Sporozoite/liver stages		
Circumsporozoite surface protein (CSP)	60 kDa	Sporozoite surface
Sporozoite surface protein-2 (SSP-2)	63 kDa	Sporozoite surface, Micronemes
Liver stage antigen-1 (LSA-1)	200 kDa	Parasitophorous vacuole
Sporozoite threonine asparagine rich protein (STARP)	70 kDa	Sporozoite surface
Blood stages		
Merozoite surface protein-1 (MSA-1)	195 kDa	Merozoite surface
Merozoite surface antigen-2 (MSA-2)	45 kDa	Merozoite surface
Apical membrane antigen-1 (AMA-1)	83 kDa	Rhoptry organelle
Rhoptry antigen protein-1 (RAP-1)	80 kDa	Rhoptry organelle
Rhoptry antigen protein-2 (RAP-2)	42 kDa	Rhoptry organelle
Ring erythrocyte surface antigen (RESA)	155 kDa	Dense granules
Acid base rich antigen (ABRA)	75 kDa	Parasitophorous vacuole
Histidine rich protein-2 (HRP-2)	65 kDa	Secreted into plasma
Serine repeat antigen (SERA)	110 kDa	Released at rupture
Pf Erythrocyte membrane protein-1 (PfEMP-1)	250-400 kDa	Parasitized erythrocyte surface
Erythrocyte binding antigen-175 (EBA-175)	175 kDa	Micronemes/Apical end
Thrombospondin related anonymous protein (TRAP)/(SSP-2) ?	63 kDa (?)	(?)

Table 2. Multiple epitope peptides developed at ICGEB

Peptide	Sequence	Antigen
P1	LDNIGNVVGKNEDYIKKNKPYSLFQKEKMVLGP GEENV EHD A EENVEENV	MSP-1/RESA
P18	EWSPCSVTCGNGIQVRIK	CSP
P32	IEQYLKKIKNSISTEWSPCSVTCGNGIQVRIK	CSP
P60	IEQYLKKIKNSISTEWSPCSVTCGNGIQVRIKP GSANKPKDEL DYENDIEKKICKMEKCS	CSP

the manner in which this can be done still needs to be worked out. Design of synthetic peptides containing disease relevant B and T epitope sequence in order to generate specific immune responses is central to the development of peptide vaccines.

Carboxy-terminal to the repeats, CS proteins from all *Plasmodium* species possess a conserved region (region II) centered around a cysteine containing nonapeptide sequence, WSPCSVTCG, also found in proteins involved in cell-cell interactions, such as thrombospondin, properdin, etc. Results from our laboratory and the works of others have clearly indicated that region II is a sporozoite ligand for the hepatocyte receptor^{44,45}. We were able to show that two peptides, based on the *P. falciparum* region II sequence, P18 and P32 (Table 2) significantly inhibited *P. berghei* sporozoite invasion into HEP-G2 cells⁴⁵. Quite significantly, we also found that antibodies to P32 also inhibited *P. berghei* sporozoite invasion of Hep-G2 cells. Since P32 contains a strong T-cell determinant in addition to the conserved region II motif, we immunized mice with P32 without using a carrier protein. Significant immune re-

sponses were obtained in two different strains of mice. The fact that immunization of mice with P32, without the use of a carrier protein, protected them against a lethal challenge of *P. berghei* sporozoites strongly suggests that P32 contains crucial B and T-cell epitopes and that region II may be useful as a component of a malaria vaccine⁴⁵.

Surprisingly the conserved nonapeptide sequence of the region II is also present in another sporozoite surface antigen called thrombospondin related adhesive protein (TRAP or SSP-2), which also has been recognized to play a crucial role in the sporozoite invasion of hepatocytes⁴⁶. Although first described from the blood stages, the expression of TRAP during the erythrocytic stages of the parasites has been controversial⁴⁶. We have found that antibodies raised against a synthetic peptide containing the conserved nonapeptide motif recognized a protein in the blood lysate of *P. falciparum* culture⁴⁷. Immunoprecipitation experiments with antibodies raised against recombinant TRAP, and its fragments, provided further evidence for the presence of a TRAP-like protein during the blood stages of *P. falciparum*. Further, we

found that anti-peptide antibodies inhibited merozoite invasion of erythrocytes⁴⁷. Mice immunized with synthetic peptides P32 or P60 (Table 2), both of which contain several B and T epitopes (Figure 1a) including the region II sequence, were partially protected against a heterologous challenge with blood stage parasites of *P. yoelii*⁴⁸. Immunization with P60 in rhesus monkeys also produced high anti-peptide antibody response. Protection experiments in Aotus monkeys with P60 have been planned. Fine specificity of the immune responses to these peptides with respect to various B and T-epitopes showed that the response was focused on the region II sequence. From the cytokine analysis data we observed that both Th1 and Th2 cellular responses were induced upon immunization with the peptides⁴⁸. Our results clearly show that through the use of appropriate peptide it may indeed be possible to focus the immune response to the regions which otherwise remain largely cryptic during the course of natural infection or upon immunization with recombinant or native proteins.

It is generally believed that a future malarial vaccine will need to contain a combination of different antigens. Synthetic peptide constructs containing B and T-epitopes from different antigens have been developed, but a major concern with epitope-based constructs is the genetic restriction of the immune response in an outbred human population. Characterization of B and T-cell determinants in a viral or parasite antigen may be relatively simple now, given the advances in peptide synthesis, theoretical prediction of antigenic sites and a battery of simple assays. We have analysed immune responses to a series of synthetic peptides representing predicted B and T-cell determinants from conserved regions of MSP-1, TRAP, RESA and AMA-1. Analysis of the development of immune response to specific immunodominant peptide fragments from different major malaria antigens revealed a direct correlation of malaria-specific antibodies with transmission of the disease²⁶. One of the peptides, representing repeat structure peptide of RESA has turned out to be a good marker and may be used as a capture antigen in ELISA to determine the status of malaria control programme⁴⁹.

Based on B and T-cell epitopes of liver and blood stage antigens, CS protein, and MSP-1 and RESA, respectively, two multiple epitope peptides, P1 and P2 (ref. 50) were designed and synthesized (Table 2). These linear peptides were highly immunogenic in mice without the use of a carrier protein and both peptides were able to induce cellular proliferative responses⁵¹. We also studied the effect of different adjuvants on the immunogenicity of these peptides and found that in alum also these peptides are excellent antigens. Interestingly immunization with P1 (Figure 1b) provided protection to BALB/c mice against a heterologous, *P. yoelii* challenge infection. However, P2, which also contains similar B and T epitopes, but in different orientation, failed

to provide any protection. We found that in case of P2 immunization the humoral response was focused on T-epitope sequence instead of the B-cell determinant⁴⁴. Our results suggest, as indeed from several other groups working on peptide vaccines, that while linear multiple epitope peptides may offer attractive alternatives as subunit vaccines, it is clear that ground rules for the design of such immunogenic peptides are yet to be defined⁵¹⁻⁵³.

It is obviously important to analyse whether the epitopic sequences from malaria antigens are immunogenic in the context of infected individuals living in malaria-endemic areas. Even though most of our work involves the use of highly-conserved regions of the vaccine target antigens, it will be of relevance to characterize these antigens from Indian isolates of *P. falciparum*; surprisingly none of these antigens have been characterized as yet. As a step in this direction we have isolated, cloned and sequenced the gene of the MSP-2 from three geographical isolates from different malaria-endemic areas in India. The MSP-2 gene of Indian isolates is remarkably similar to the FC-27 strain from Papua, New Guinea⁵⁴. We are now in the process of characterizing genes of MSP-1, CS protein, TRAP and AMA-1 of *P. falciparum* from Indian isolates.

P. vivax/P. cynomolgi malaria

Of all the malaria cases in India up to 60 to 70% are due to *Plasmodium vivax* infection and although *P. vivax* infection does not directly kill the host, it causes a great deal of discomfort and morbidity. Relatively less is known about the immune responses of the host to *P. vivax* infection. Also, the antigens of *P. vivax* are not as well characterized as *P. falciparum*, mainly because unlike *P. falciparum*, *P. vivax* has resisted all attempts of culturing the parasite; infected humans remain the only source of the parasite material. *Plasmodium cynomolgi* is a simian malaria which is closely related to *P. vivax* in taxonomy and morphology, and is regarded as a good model to study the *P. vivax* infection⁵⁵. We have characterized genes of three major vaccine target antigens from a *P. cynomolgi* isolate, obtained from the Central Drug Research Institute, Lucknow, in order to test their potential as vaccine candidates in the readily available rhesus monkey model. We found that the AMA-1 of *P. cynomolgi* is closely related to the *P. vivax* counterpart, and most structural features like number and position of cysteine residues and proline residues are conserved in the two homologues⁵⁶. The full length AMA-1 and a truncated version of it have been expressed in *E. coli* and baculovirus system, in our laboratory. This will allow us to investigate the immune responses to Pc AMA-1 in the monkey model, and thus to analyse its role in protective immunity during the blood stages of the parasite.

Another important vaccine target antigen, TRAP, is also a major focus in our laboratory for analysing its role in malaria immunity. We have observed that certain highly conserved B-cell epitopes of the Pf TRAP remain cryptic during the course of natural infection. The ability to make important functional epitopes cryptic appears to be a general strategy of parasites to evade host's immune responses as has been shown in case of surface protein of *Trypanosoma cruzi*⁵⁷. We have cloned and expressed in bacteria the full length TRAP gene of *P. falciparum* from an Indian isolate, and its fragments, representing the N and C-terminal domains of the protein. Since TRAP is considered one of the most conserved malaria antigens, we have also characterized the TRAP gene from *P. cynomolgi*⁵⁸. The potential of this antigen and their fragments in protection will be tested in a relevant animal model. Since TRAP is highly conserved across the *Plasmodium* species, the results of *P. cynomolgi* experiments will be of direct relevance in evaluating its role in *P. vivax* and *P. falciparum* vaccine development.

As mentioned earlier, it appears that the ability to block the development of immune responses to the functional epitopes is one of the main strategies to evade immune responses of the host. This is why a synthetic peptide-based vaccine development approach may be most relevant in a parasite disease like malaria. Through the use of peptides it may be possible to focus immune responses to the otherwise cryptic epitopes; development of synthetic peptides as immunogens is, therefore, an immediate need for parasite vaccines. However, genetic restriction of immune response, specificity of epitopic sequences, use of appropriate adjuvants, etc. are some of the problems that will have to be sorted out before peptides may be useful for vaccination. With the availability of recombinant antigens and their fragments in our laboratory, it should now be possible for us to compare the immune responses obtained upon immunization with whole antigens with those obtained from the use of synthetic, multiple epitope peptides. For the development of vaccines against parasitic diseases, this appears to be one of the most important questions.

1. Romero, P., *Curr. Opin. Immunol.*, 1992, 4, 432-441.
2. Hoffman, S. L., *Clin. Microbiol. Rev.*, 1994, 1, 303-310.
3. Taverne, J., Bate, C. A. W., Kwiatkowski, D., Jakobsen, P. H. and Playfair, J. H. L., *Infect. Immun.*, 1996, 58, 2923-2928.
4. Sabchareon, A., Burnouf, D., Quattara, et al. *Am. J. Trop. Med. Hyg.*, 1991, 45, 297-308.
5. Nussenzweig, R. S., Vanderberg, J., Most, H. and Orton, C., *Nature*, 1967, 216, 160-162.
6. Nussenzweig, R. S., Vanderberg, J., Most, H. and Orton, C., *Nature*, 1969, 222, 488-489.
7. Herrington, D., Davis, J., Nardin, E. et al., *Am. J. Trop. Med. Hyg.*, 1991, 45, 539-547.
8. Khusmith, S., Charoenvit, Y., Kumar, S., Sedegah, M., Beau-doin, R. L. and Hoffman, S. L., *Science*, 1991, 252, 715-718.

9. Siddiqui, W. A., Tam, L. Q., Kramer, K. J. et al. *Proc. Natl. Acad. Sci. USA*, 1987, 84, 3014-3018.
10. Knapp, B., Hundt, F., Enders, B. and Kupper, H. A., *Infect. Immun.*, 1992, 60, 2397-2401.
11. Ballou, W. R., Hoffman, S. I., Sherwood, J. E. et al., *Lancet*, 1987, 1, 1277-1281.
12. Liew, F. Y., *Vaccination Strategies of Tropical Diseases*, CRC Press, 1989.
13. Schultze, M. P., Leclerc, C., Jolivet, M., Audibert, F. and Chedid, L., *J. Immunol.*, 1985, 135, 2319-2322.
14. LeClerc, C., Przewlocki, G., Schultz, M. P. and Chedid, L. A., *Eur. J. Immunol.*, 1987, 17, 269-273.
15. Di Marchi, R., Brooke, G., Gale, C., Cracknell, V., Doel, T. and Mowat, N., *Science*, 1986, 232, 639-641.
16. Kumar, A., Arora, R. K., Kaur, P., Chauhan, V. S. and Sharma, P., *J. Immunol.*, 1992, 148, 1499-1505.
17. Sedegah, M., Hedstrom, R. A., Hobart, P. and Hoffman, S. L., *Proc. Natl. Acad. Sci. USA*, 1994, 91, 9866-9870.
18. Nardin, E. H. and Nussenzweig, R. S., *Annu. Rev. Immunol.*, 1993, 11, 687-727.
19. Herrington, D. A., Clyde, D. F., Losonsky, G. et al., *Nature*, 1987, 328, 257-259.
20. Herrington, D. A., Nardin, E. H. and Losonsky, G. et al., *Am. J. Trop. Med. Hyg.*, 1991, 45, 695-701.
21. Schofield, L., Villagiuran, J., Ferreira, H., Schellekens, H. and Nussenzweig, R., *Nature*, 1988, 330, 664-666.
22. Khusmith, S., Sedegah, M. and Hoffman, S. L., *Infect. Immun.*, 1994, 62, 2979-2983.
23. Fidcock, D. A. and Druilhe, P., *J. Immunol.*, 1994, 153, 190-204.
24. Etlinger, H., Caspers, P., Matile, H., Schoenfeld, H. J., Stueber, D. and Tackas, B., *Infect. Immun.*, 1991, 59, 3498-3503.
25. Herrera, M. A., Rosero, F., Herrera, S., Caspers, P., Rotmann, D., Singaglia, F. and Certa, V., *Infect. Immun.*, 1992, 60, 154-158.
26. Kabilan, L., Sharma, V. P., Kaur, P., Ghosh, S. K., Yadav, R. S. and Chauhan, V. S., *Infect. Immun.*, 1994, 62, 685-691.
27. Blackman, M. J., Heidrich, H. G., Donachie, S., McBride, J. S. and Holder, A. A., *J. Exp. Med.*, 1990, 172, 379-382.
28. Saul, A., Lord, R., Jones, G. L. and Spencer, L., *J. Immunol.*, 1992, 148, 208-211.
29. Waters, A. P., Thomas, A. W., Deans, J. A., Cohen, S. et al., *J. Biol. Chem.*, 1990, 265, 17974-17979.
30. Howard, R. J. and Pasloske, B. J., *Parasitol. Today*, 1993, 9, 369-372.
31. Long, C. A., *Curr. Opin. Immunol.*, 1993, 5, 548-556.
32. Valero, M. V., Amador, L. R., Galindo, C. et al., *Lancet*, 1993, 341, 705-710.
33. Alonso, P. L., Smith, T., Armstrong Schellenberg, J. R. M. et al., *Lancet*, 1994, 344, 1175-1181.
34. D'Alessandro, U., Leach, A., Drakeley, C. J. et al., *Lancet*, 1993, 346, 462-467.
35. Nosten, F., Luxemburger, C., Kyle, D. E. et al., *Lancet*, 1996, 348, 701-707.
36. Patarroyo, M. E., Romero, P., Torres, M. et al., *Nature*, 1987, 328, 629-632.
37. Patarroyo, M. E., Romero, P., Torres, M. et al., *Nature*, 1988, 332, 158-161.
38. Newbold, C. I., *BMJ*, 1992, 304, 451.
39. Ruebush, T. K., Cambell, G. H., Moreno, A. et al., *Am. J. Trop. Med. Hyg.*, 1990, 43, 355-366.
40. Herrera, S., Herrera, M. A., Clavijo, C. et al., *Acta Leidensia*, 1991, 60, 107-110.
41. Kemp, D. J., Coppel, R. L. and Anders, R. F., *Annu. Rev. Microbiol.*, 1987, 41, 181-194.
42. Anders, R. F., *Parasite Immunol.*, 1986, 8, 529-539.

43. Kaur, P., Sharma, P., Kumar, A. and Chauhan, V. S., *Int. Pept. Protein Res.*, 1990, **36**, 515–521.
44. Cerami, C., Frevert, U., Sinnis, P., Tackacs, B., Clavejo, P., Santos, M. J. and Nussenzweig, V., *Cell*, 1992, **70**, 1021–1033.
45. Chatterjee, S., Wery, M., Sharma, P. and Chauhan, V. S., *Infect. Immun.*, 1995, **63**, 4375–4381.
46. Muller, H. M., Reckman, I., Hollingdale, M. R., Bujard, H., Robson, K. J. H. and Crisanti, A., *EMBO J.*, 1993, **12**, 2881–2889.
47. Sharma, P., Bharadwaj, A., Bhasin, V. K., Sailaja, V. N. and Chauhan, V. S., *Infect. Immun.*, 1996, **64**, 2172–2179.
48. Bharadwaj, A., Joshi, S. K., Sharma, P., Sailaja, V. N. and Chauhan, V. S., *J. Immunol.*, Communicated.
49. Roy, A., Sharma, V. P. and Chauhan, V. S., *J. Immunol. Method*, 1994, **167**, 139–143.
50. Chauhan, V. S., Chatterjee, S. and Johar, P. K., *Parasite Immunol.*, 1993, **15**, 239–242.
51. Chatterjee, S., Sharma, P., Kumar, S. and Chauhan, V. S., *Vaccine*, 1995, **13**, 1474–1481.
52. Cox, J. H., Ivanyi, J., Young, D. B., Lamb, J. R., Syred, A. D. and Francis, M. J., *Eur. J. Immunol.*, 1988, **18**, 2015–2019.
53. Vijaykrishnan, L., Kumar, V., Agrewala, J. N., Mishra, G. C. and Rao, K. V. S., *J. Immunol.*, 1994, **153**, 1613–1625.
54. Bhattacharya, P., Malhotra, P., Sharma, P., Okenu, D. M. and Chauhan, V. S., *Mol. Biochem. Parasitol.*, 1995, **74**, 125–127.
55. Escalante, A. A. and Ayala, F. J., *Proc. Natl. Acad. Sci. USA*, 1994, **91**, 11373–11377.
56. Dutta, S., Malhotra, P. and Chauhan, V. S., *Mol. Biochem. Parasitol.*, 1995, **73**, 267–270.
57. Wrightsman, R. A., Dawson, B. D., Fouts, D. L. and Manning, J. E., *J. Immunol.*, 1994, **153**, 3148–3154.
58. Sejwali, P., Malhotra, P., Puri, S. K. and Chauhan, V. S., *Mol. Biochem. Parasitol.*, submitted.

ACKNOWLEDGEMENTS. I wish to thank our collaborators outside ICGEB and my colleagues at ICGEB for their help and involvement in the work presented in this report. In particular I would like to acknowledge continuous support of Dr V. P. Sharma and his colleagues at the Malaria Research Centre, Delhi.

Received 4 December 1996; accepted 5 December 1996

RESEARCH ARTICLES

What's the essence of royalty – one keto group?

Raghavendra Gadagkar

Centre for Ecological Sciences, Indian Institute of Science, Bangalore 560 012, India and Jawaharlal Nehru Centre for Advanced Scientific Research, Jakkur, Bangalore 560 064, India

A honey bee colony consists of a single queen, tens of thousands of nearly sterile female workers and usually a few hundred drones. The presence of the queen inhibits rearing of new queens, stimulates foraging and interaction of workers with the queen and, (along with the queen's brood), inhibits the development of worker ovaries. Most or all of these effects of the queen on the workers are mediated through primer pheromones secreted by the queen. An important component of the queen's pheromone blend is 9-keto-(E) 2-decenoic acid (9-ODA). Workers also produce related substances which appear to function as nutrients and food preservatives. A dominant component of the worker blend is a diacid which is made from a precursor molecule hydroxylated at the ω

carbon atom rather than at the $\omega-1$ carbon atom. The $\omega-1$ precursor is used by the queen which leads to the formation of a keto acid. One might say that the fundamental difference between a queen and worker, the essence of royalty is therefore, one keto group! The recently-elucidated caste-specific biosynthetic pathway for the production of these pheromones permits two other speculations. One is that workers can be thought of as being closer to the ancestral solitary condition and that queens can be thought of as a derived invention of sociality. The other is that, compared to non-social species, social insects are especially predisposed to evolve novel structures and characters as exemplified by the queen for example, through the process of evolution of gene duplication.

Honey bees

WILLIAM Morton Wheeler¹ says of the honey bee: 'Its sustained flight, its powerful sting, its intimacy with flowers and avoidance of all unwholesome things, the

attachment of the workers to the queen – regarded throughout antiquity as a king – its singular swarming habits and its astonishing industry in collecting and storing honey and skill in making wax, two unique substances of great value to man, but of mysterious origin,