

SOME RECENT ADVANCES IN DIGITAL DIFFERENTIATORS*

S. C. DUTTA ROY

Department of Electrical Engineering, Indian Institute of Technology, New Delhi 110 016, India.

ABSTRACT

A new class of digital differentiators, based on maximal linearity at a specific frequency as the criterion, is described. These designs are shown to be superior compare to those based on minimax relative error criterion for restricted ranges of frequency in the low, middle and high frequency bands. A universal differentiator design has also been described, which represents a distinct advance in the state of the art.

INTRODUCTION

IN this lecture, I shall concentrate on the design of finite impulse response (FIR) digital differentiators (DD), primarily because the results we obtained recently in this field are very significant and are in contrast to the long-standing belief that the best differentiators are those that use the well-known minimax relative error (MRE) approximation. The latter designs have been extensively investigated by Rabiner and co-workers¹⁻³, and beyond formulating the minimization problem, the designs are totally algorithmic, and hence computer-aided. It has been our aim, for the last several years, to establish digital signal processor designs on the same rigorous analytical base as their analog counterparts. To this end, we have previously investigated variable digital filters⁴⁻⁸ and maximally flat FIR filters⁹⁻¹², and obtained some remarkable results. Application of the same insistence on analytical rigour, rather than the algorithmic approach, has led to explicit mathematical formulas and elegant analytical designs for DD's, as will be illustrated in this lecture.

I must mention, at the very outset, that MRE designs are indeed very attractive when one requires a wideband performance. In most

of the practical applications, however, one requires good differentiation over a limited range of frequencies, and MRE designs cannot efficiently be adopted for such situations. Over-performance in differentiation has its own disadvantage in communication, viz. it accentuates out-of-band noise. Our designs, which use maximal linearity as the criterion, appear to be ideally suited for such applications. The criterion itself leads to precise mathematical formulation and solution, thus obviating the necessity of undue dependence on numerical procedures and guarding against the associated problem of sensitivity to finite word length. A very remarkable by-product of our investigations is a novel and efficient architecture of digital differentiators for variable frequency range of operation, where, simply by changing the tap, one can obtain a desired range without changing any internal structure. This has opened up the possibility of fabricating a universal differentiator chip, and has led to a patent application¹³, which we hope will be granted soon.

THE PROBLEM

Let us now look at the problem. An ideal DD has the frequency response

$$\tilde{H}_d(\omega) = j\omega \triangleq j\tilde{H}(\omega), \quad -\pi \leq \omega \leq \pi, \quad (1)$$

where $\tilde{H}(\omega) = \omega$ is purely real (figure 1). The frequency ω is of course in the normalized

*Text of an invited lecture delivered at the 54th Annual Meeting of the Indian Academy of Sciences, held at the Indian Association for the Cultivation of Science, Calcutta, on 31 October 1988.

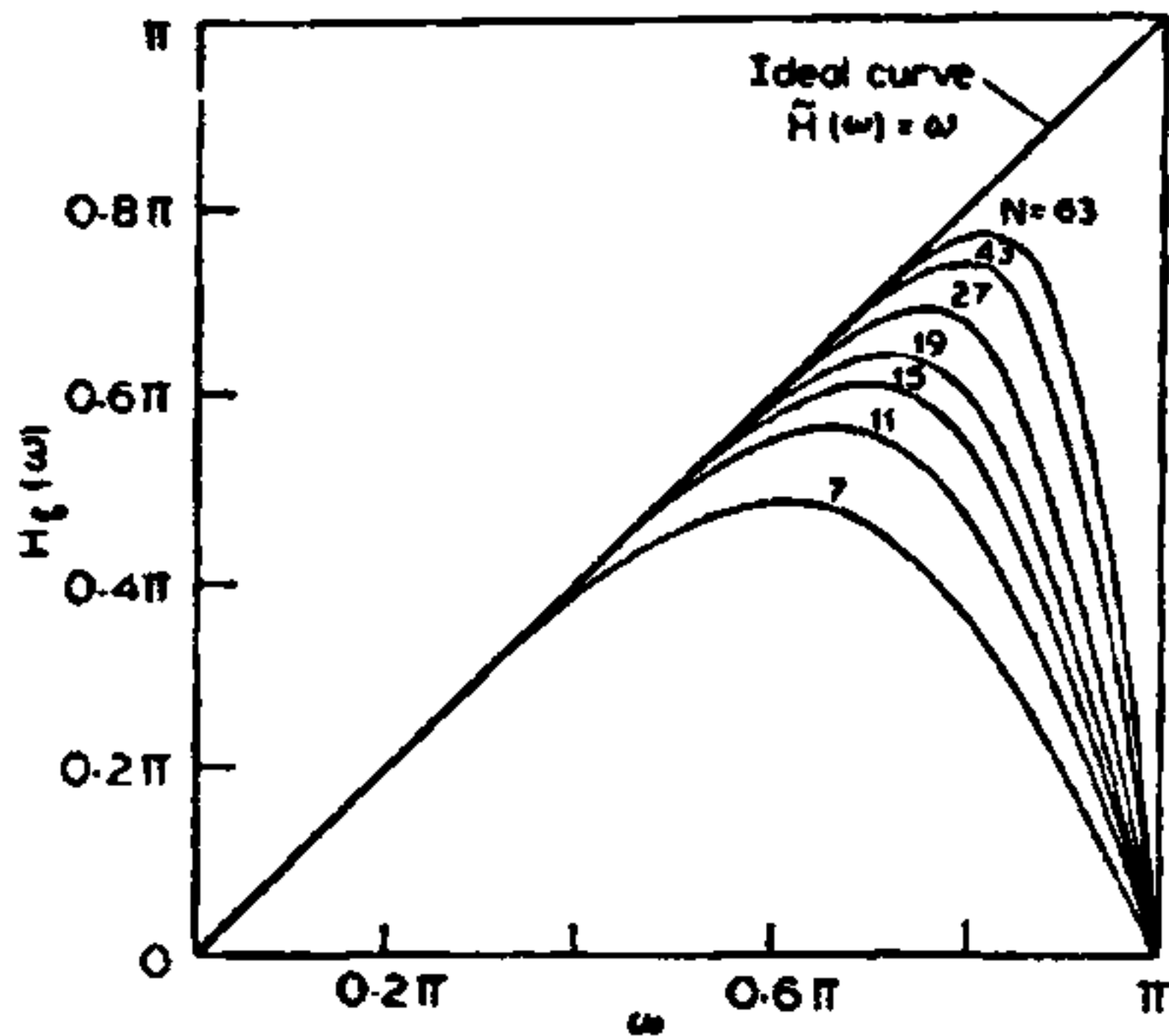

Figure 1. Frequency response $H_l(\omega)$ of maximally linear (at $\omega=0$) DD for various values of N .

digital scale, $0 \leq \omega \leq \pi$ being the baseband. We approximate $\hat{H}(\omega)$ with maximal linearity at $\omega=0$ or $\pi/2$ or π for low, mid and high frequency bands respectively; the corresponding frequency responses will be indicated by the subscripts l, m or M , and h . The relative error (RE), in percentage, will be defined as

$$RE \triangleq 100 \left| \frac{|H(\omega)| - |\hat{H}(\omega)|}{|\hat{H}(\omega)|} \right| \omega, \quad (2)$$

where $H(\omega)$ is the approximating function. Note that (2) involves only the magnitude error. This is so because, in most of the practical applications, the phase error is either unimportant or can be made zero.

DD'S FOR LOW FREQUENCIES

Typical applications of low frequency DD's are Doppler radar and sonar, auto-pilotage, auto-navigation and weapon control systems. The simplest approximation to $j\omega$ for low frequencies is $j \sin \omega$, which can be written as $(e^{j\omega} - e^{-j\omega})/2$ and realized as $(z - z^{-1})/2$ or $(1 - z^{-2})/2$, where, in the last form, there is an additional linear phase, equal to $-\omega$. Also, the length of the impulse response is 3, the values being $h_0 = 1/2$, $h_1 = 0$ and $h_2 = -1/2$, which shows antisymmetry. This simple example motivates us to assume a general approximation to $\hat{H}(\omega) = \omega$ of the form

$$H_l(\omega) = \sum_{i=1}^n d_i \sin(i\omega), \quad (3)$$

where $n = (N-1)/2$, N being the length of the filter, and is assumed to be odd for well-known reasons. We now force maximal linearity at $\omega=0$ by demanding the following:

$$H_l(\omega) \Big|_{\omega=0} = 0 \quad (4)$$

$$dH_l(\omega)/d\omega \Big|_{\omega=0} = 1 \quad (5)$$

$$d^u H_l(\omega)/d\omega^u \Big|_{\omega=0} = 0, \quad u = 2, 3, \dots, 2n-1. \quad (6)$$

Obviously, (4) is satisfied by (3); on the other hand, (5) and (6) yield n non-trivial equations, which can be put in the matrix form

$$\begin{bmatrix} 1 & 1 & 1 & \dots & 1 \\ 1 & 2^2 & 3^2 & \dots & n^2 \\ 1 & 2^4 & 3^4 & \dots & n^4 \\ \dots & \dots & \dots & \dots & \dots \\ 1 & 2^{2n-2} & 3^{2n-2} & \dots & n^{2n-2} \end{bmatrix} \begin{bmatrix} d_1 \\ 2d_2 \\ 3d_3 \\ \dots \\ nd_n \end{bmatrix} = \begin{bmatrix} 1 \\ 0 \\ 0 \\ \dots \\ 0 \end{bmatrix}. \quad (7)$$

Crout's method is used to solve (7), and results in the following recursive formula¹⁴ for d_i :

$$d_i = \frac{(-1)^{i+1}}{i \binom{2i-1}{i-1}} - \sum_{r=1}^{n-i} \binom{2i+r-1}{2i-1} d_{i+r}, \quad (8)$$

$i = n, n-1, n-2, \dots, 1,$

where $\binom{0}{k}$ is defined as 1 for $k=0$ and 0 for $k \neq 0$.

Another route to compute d_i s is based on the observation that $d\hat{H}(\omega)/d\omega$ is a rectangular pulse of unit height for $-\pi \leq \omega \leq \pi$. If this is approximated by a lowpass characteristic $H_L(\omega)$ with maximal flatness at $\omega=0$, then $\int_0^\omega H_L(\omega) d\omega$ should give us an approximation to

$\tilde{H}(\omega)$ with maximal linearity at $\omega=0$. The maximally flat lowpass case was extensively investigated earlier^{9,10}, and led to explicit formulas for its coefficients a_i , $i=0$ to n . In terms of a_i , we have established that

$$d_i = a_i/[i(1-a_0)], \quad i=1, 2, \dots, n. \quad (9)$$

If, in (9), one substitutes the explicit expressions for a_i , then some relatively tricky combinatorial manipulations lead to the following explicit formula¹⁵ for d_i :

$$d_i = \left[i \binom{2n-1}{n-1} \right]^{-1} \sum_{k=0}^{n-1} (-1)^k \binom{n}{k} \sum_{q=0}^{2k} (-1)^q \binom{2k}{q} \binom{2n-2k}{n-i-q},$$

$$i=1, 2, 3, \dots, n. \quad (10)$$

Of the three methods for computing d_i s, as given by (8), (9) and (10), the recursive formula (8) takes the smallest computation time. This is, of course, expected.

The performance of the maximally linear (ML) differentiator for low frequencies is shown in figure 1. Note that extremely high accuracies are indeed achievable. For example, for an RE ≤ -200 dB in the range $0 \leq \omega \leq 0.20\pi$, the MRE design requires $N=127$, whereas our design can achieve the same with $N=21$ only.

DD'S FOR MIDBAND FREQUENCIES

In many communication systems applications, e.g. interferometer radar and phase comparison monopulse radar, differentiators having the highest accuracy in the midband frequencies of the spectrum are needed, because the most vital information is contained therein. The MRE designs for such cases require the use of half-a-sample delay/advance together with an even N . Nonintegral delay is undesirable, particularly in large signal processing systems, while even N deprives the system of allied possible advantages, e.g. achieving diffe-

rentiation through FFT on a general-purpose computer, when N is large. The ML designs, as we shall show, obviate these disadvantages.

First, we consider an approximation to the magnitude function, of the form

$$H_m(\omega) = d_0 + \sum_{i=1}^n d_i \cos(i\omega),$$

$$n=(N-1)/2, N \text{ odd.} \quad (11)$$

Maximal linearity at $\omega = \pi/2$ demands

$$H_m(\omega) \Big|_{\omega=\pi/2} = \pi/2 \quad (12)$$

$$dH_m(\omega)/d\omega \Big|_{\omega=\pi/2} = 1 \quad (13)$$

$$d^u H_m(\omega)/d\omega^u \Big|_{\omega=\pi/2} = 0,$$

$$u=2, 3, \dots, n. \quad (14)$$

Note, from figure 2, that $|\tilde{H}_d(\omega)| = |\tilde{H}(\omega)|$ is periodic in ω with period 2π , symmetric about $(0, 0)$ and antisymmetric about $(\pi/2, \pi/2)$. If we wish these features to be retained in $H_m(\omega)$, then it is easily shown that (11) modifies to

$$H_m(\omega) = (\pi/2) + \sum_{i=1}^n d_i \cos(i\omega), \quad n \text{ odd.} \quad (15)$$

Now applying (12)–(14) on (15), and solving the resulting set of equations, we get the following recursion formula¹⁶ for d_i :

$$-id_i = \frac{\binom{i-2}{i-1}}{2^{2i-3} + \binom{0}{i-1}} + \sum_{k=\frac{i+1}{2}}^{\frac{n-1}{2}} (-1)^{\frac{2k+i-1}{2}} \times$$

$$\times (2k+1) \binom{\frac{2k+i-1}{2}}{\frac{2k-i+1}{2}} d_{2k+1}, \quad (16)$$

$i=n, n-2, n-4, \dots, 3, 1; n=(N-1)/2; n$ and N odd.

The performance of $H_m(\omega)$ is shown in figure 3. For comparison with the MRE-DD, let RE

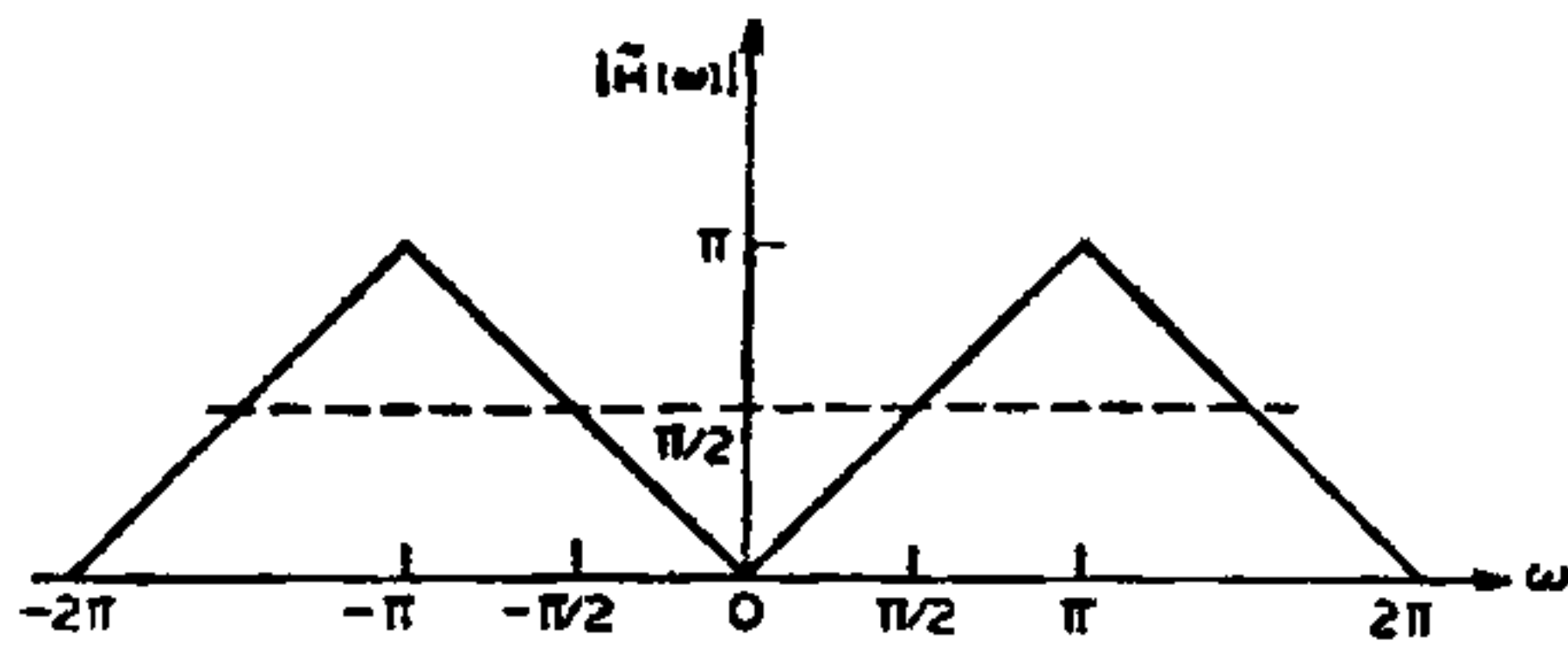

Figure 2. Frequency response of the ideal DD.

needed be ≤ -100 dB for $0.45\pi \leq \omega \leq 0.55\pi$; then ML design requires just 3 multiplications per input sample compared to 8 in MRE design. Since N is odd, no nonintegral delay is needed.

We next consider the possibility of realizing the phase exactly. For this, we choose the magnitude as

$$H_M(\omega) = \sum_{i=1}^n b_i \sin(i\omega),$$

$$n = (N-1)/2, \quad N \text{ odd}, \quad (17)$$

$$= (\pi/2) \sum_{\substack{i=1 \\ i \text{ odd}}}^{n-1} d_i \sin(i\omega) - (1/2) \sum_{\substack{i=2 \\ i \text{ even}}}^n d_i \sin(i\omega),$$

$$n \text{ even}. \quad (18)$$

We have chosen even n because actual calculations show this to be a better choice. We now impose conditions (12)–(14) on (18). This gives two sets of linear equations, solving which we arrive at the following recursion formulas¹⁷:

$$d_i = \frac{\binom{i-2}{i-1}}{2^{2i-3} + \binom{0}{i-1}} + \sum_{k=\frac{i+1}{2}}^{\frac{n-2}{2}} (-1)^{(2k+i+1)/2} \left(\frac{2k+i-1}{2} \right) \left(\frac{2k-i+1}{2} \right) d_{2k+1}, \quad (19)$$

$i = n-1, n-3, n-5, \dots, 5, 3, 1$ (descending order)

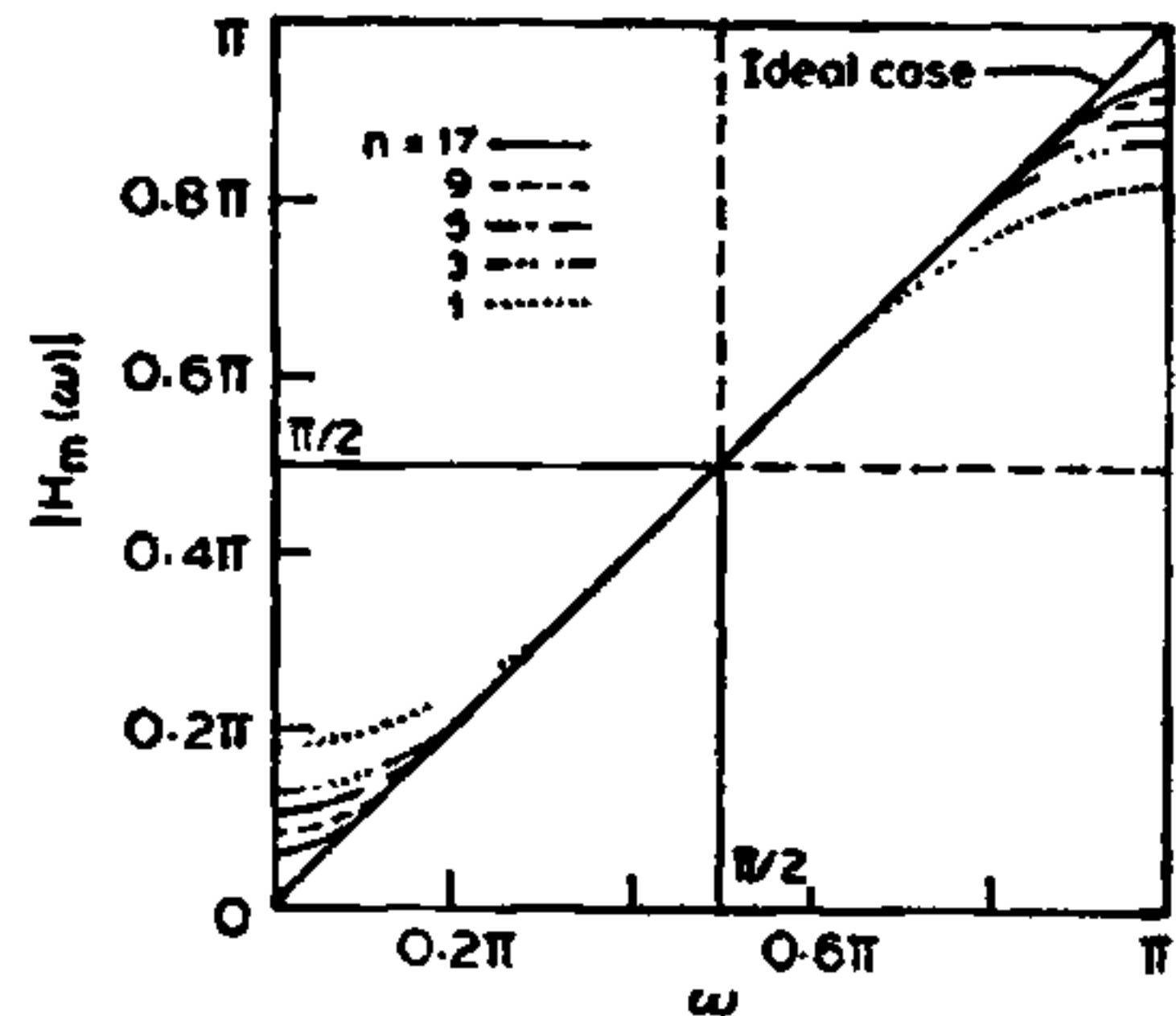

Figure 3. Frequency response $H_m(\omega)$ of maximally linear (at $\omega = \pi/2$) DD for various values of n [$= (N-1)/2$]; n also corresponds to the tap number for the case of variable frequency DD.

i odd; n even,
and

$$d_i = \frac{2}{i \binom{i-1}{i/2}} + \sum_{r=1}^{\frac{n-i}{2}} (-1)^{r+1} \binom{i+r-1}{r} d_{i+2r}, \quad (20)$$

$i = n, n-2, n-4, \dots, 6, 4, 2$ (descending order)
 i even; n even.

The performance of $H_M(\omega)$ is shown in figure 4. Again, these are superior to MRE designs over narrow bands around $\pi/2$, extending to about 25 per cent of the midband frequency spectrum.

DD'S FOR HIGH FREQUENCIES

For DDs with zero relative error at $\omega = \pi$, we have a problem. To ensure the realization of the factor j , we need an approximation of the form $\sum \sin(i\omega)$, which is identically zero at $\omega = \pi$! We can overcome this problem only by introducing a half-sample delay (i.e. a factor $z^{-1/2}$) in the structure, as in MRE designs, but we still score favourably because our designs use substantially lower orders compared to the MRE designs, for the same RE.

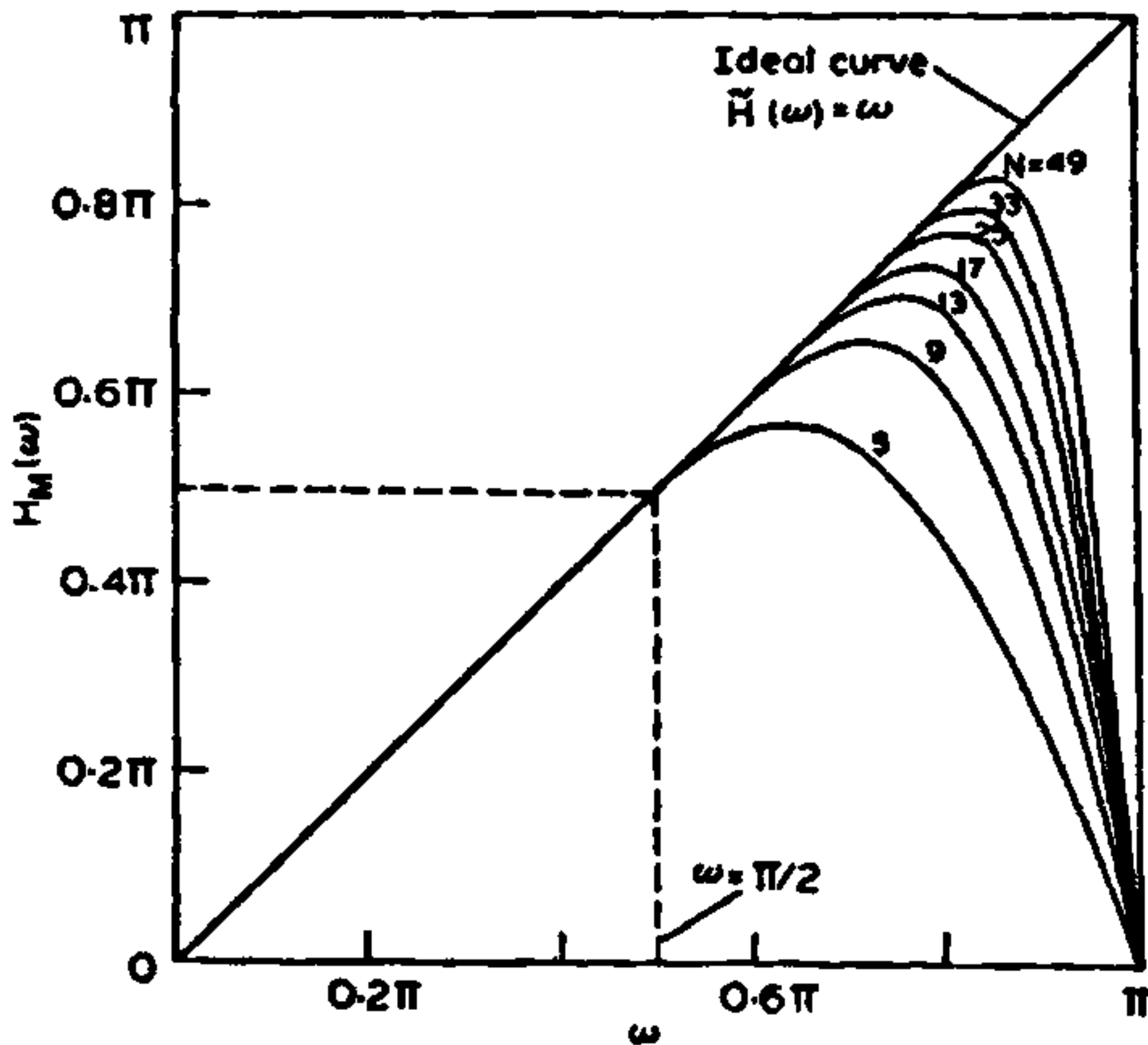

Figure 4. Frequency response $H_M(\omega)$ of maximally linear (at $\omega = \pi/2$) DD for various values of N .

We start with the function

$$H_h(\omega) = \pi \sum_{i=1}^n c_i \sin(i - \frac{1}{2})\omega - \sum_{i=1}^n d_i \sin(i\omega),$$

$n = N/2, N \text{ even}, \quad (21)$

where the first summation requires a half-sample delay for its realization. Imposing the conditions of maximal linearity, viz.

$$H_h(\omega) \Big|_{\omega=\pi} = \pi \quad (22)$$

$$\frac{dH_h(\omega)}{d\omega} \Big|_{\omega=\pi} = 1 \quad (23)$$

$$\frac{d^u H_h(\omega)}{d\omega^u} \Big|_{\omega=\pi} = 0, \quad u = 2, 3, \dots, 2n-1, \quad (24)$$

and solving the resulting sets of equations, we arrive at the following recursive formulas¹⁸ for c_i and d_i :

$$c_i = \frac{\binom{2i-3}{i-1}}{2^{4i-5} + \binom{0}{i-1}} +$$

$$+ \sum_{k=i}^{n-1} (-1)^{k+i} \binom{k+i-1}{k-i+1} c_{k+1}, \quad (25)$$

$i = n, n-1, n-2, \dots, 2, 1$ (descending order) and

$$d_i = \frac{1}{i \binom{2i-1}{i-1}} + \sum_{r=1}^{n-i} (-1)^{r-1} \binom{2i+r-1}{2i-1} d_{i+r}, \quad (26)$$

$i = n, n-1, n-2, \dots, 2, 1$ (descending order).

For causal realization, we take the transfer function to be

$$G(z) = jz^{-n} H_h(\omega) \Big|_{e^{j\omega} = z}$$

$$= (\pi/2) z^{-1/2} \sum_{i=1}^n c_i z^{-n+i} (1 - z^{-2i+1}) - (1/2) \sum_{i=1}^n d_i z^{-n+i} (1 - z^{-2i}). \quad (27)$$

A possible structure of $G(z)$ for $n=3$ ($N=6$) is shown in figure 5.

The performance of $H_h(\omega)$ is shown in figure 6. For comparison with MRE DDs, consider a specification of $RE \leq -60$ dB for $0.5\pi \leq \omega \leq \pi$. Our design requires $N=16$, whereas MRE design requires $N=128$! The ML DDs are, therefore, particularly suitable for homomor-

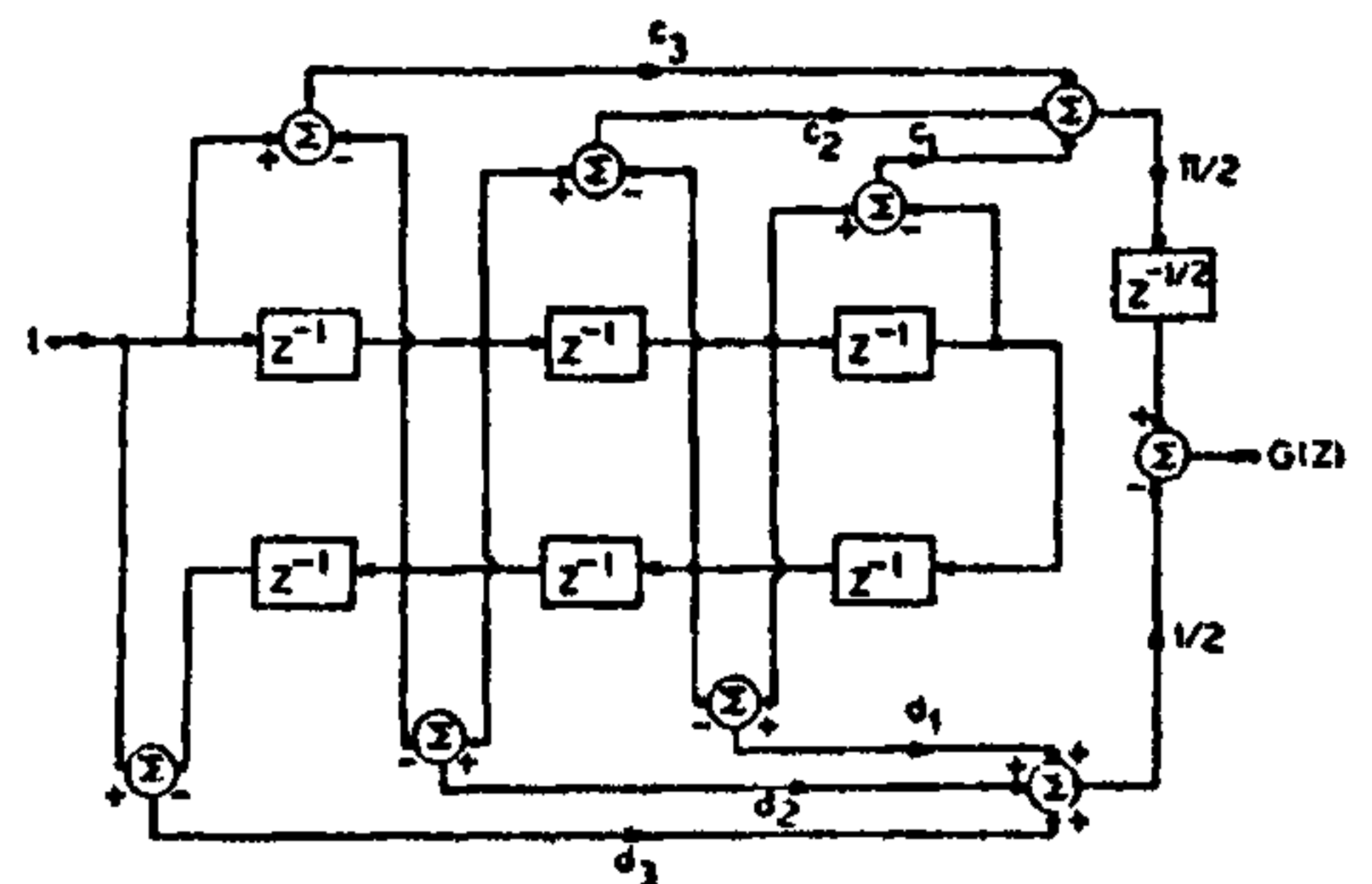

Figure 5. Realization of maximally linear (at $\omega = \pi$) DD for $N=6$.

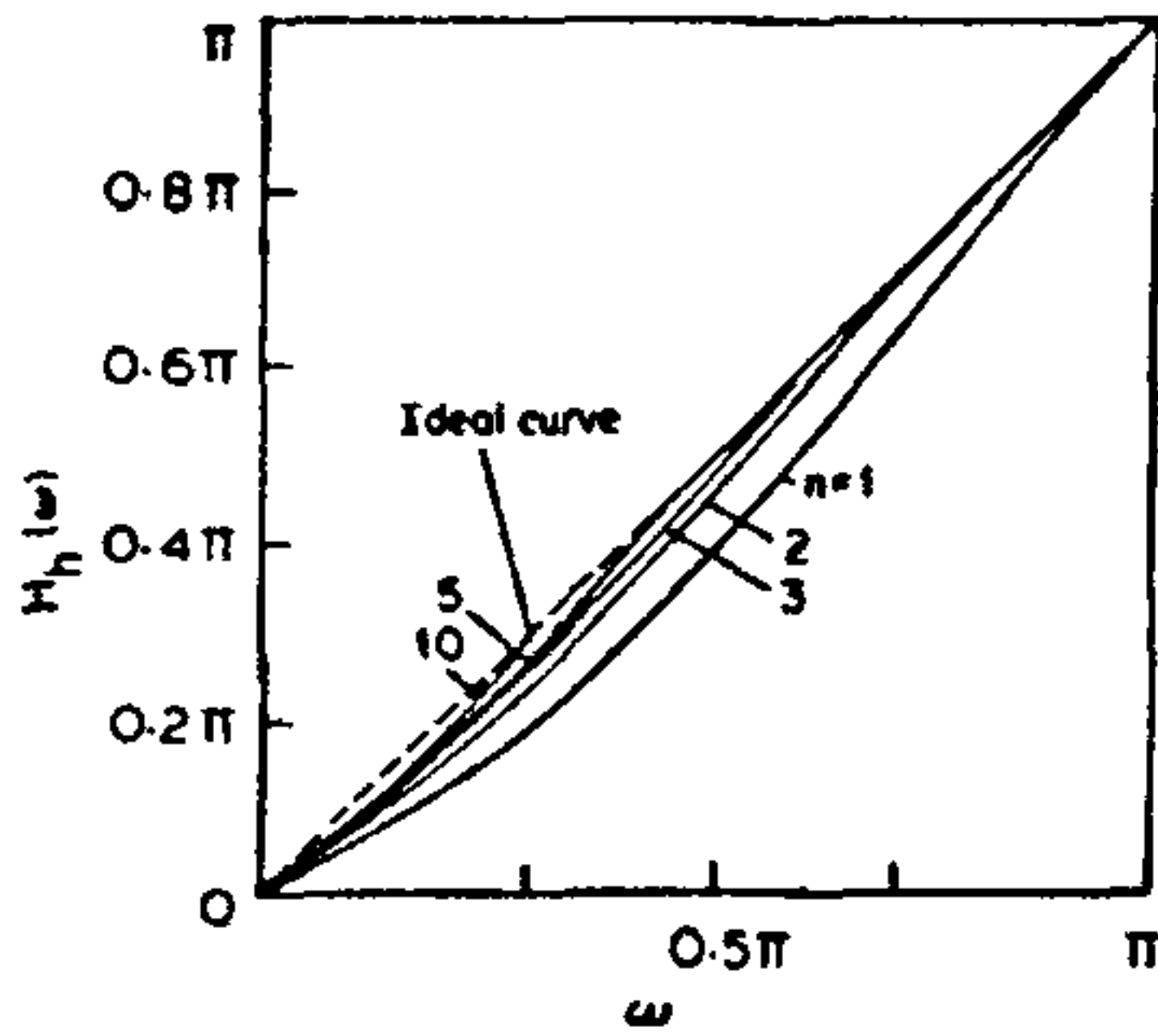

Figure 6. Frequency response $H_h(\omega)$ of maximally linear (at $\omega = \pi$) DD for various values of n .

phic processes and image enhancement applications.

VARIABLE FREQUENCY DD'S

Finally, we shall discuss a universal canonical structure which can function as a ML DD at $\omega=0$ or $\pi/2$, and which provides a variable operating frequency range around these values simply by changing the tap at which the output is taken.

Consider the function $H_m(\omega)$ of section IV:

$$H_m(\omega) = \sum_{i=0}^n d_i \cos(i\omega),$$

$$n = (N-1)/2, N \text{ odd.} \quad (28)$$

This can be expressed as

$$H_m(\omega) = \sum_{i=0}^n p_i (\cos \omega)^i. \quad (29)$$

The coefficients p_i are related to d_s through Chebyshev polynomials. Following some lengthy mathematical manipulations¹⁹, we obtain the following surprisingly simple results for p_i :

$$p_0 = \pi/2; p_1 = -1; p_j = 0, j = 2, 4, 6, \dots;$$

$$p_i = -(1/i!) [1 \times 3 \times 5 \times \dots \times (i-2)]^2,$$

$$i = 3, 5, 7, \dots \quad (30)$$

A more surprising fact to be noticed is that p_i s are independent of n ! This forms the basis of our design for variable bandwidth differentiators.

By a simple transformation of $H_m(\omega)$, we can get the corresponding $H_l(\omega)$ for variable band-

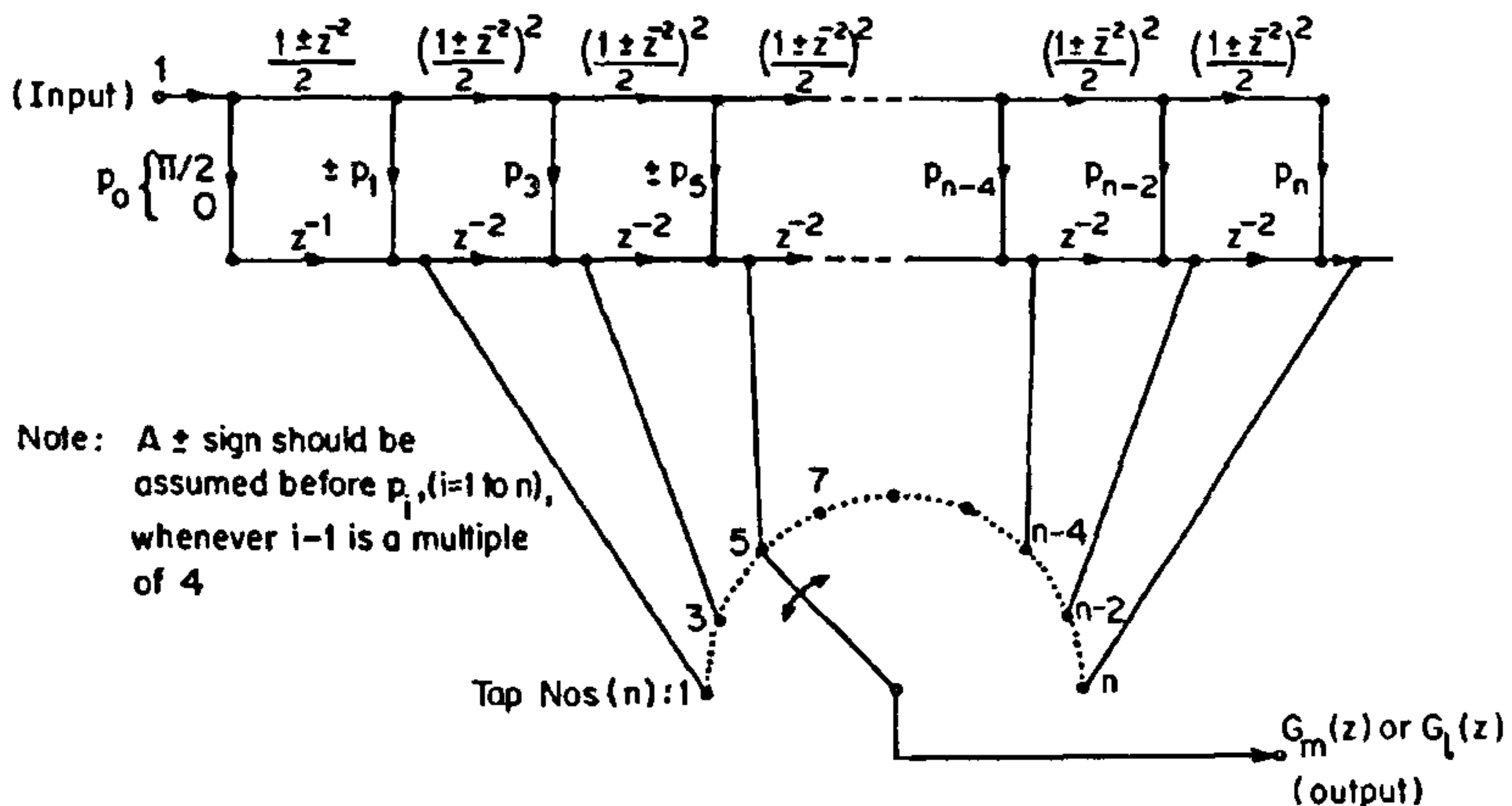

Figure 7. Realization of variable frequency range DD for low ($G_l(z)$) and midband ($G_m(z)$) frequencies.

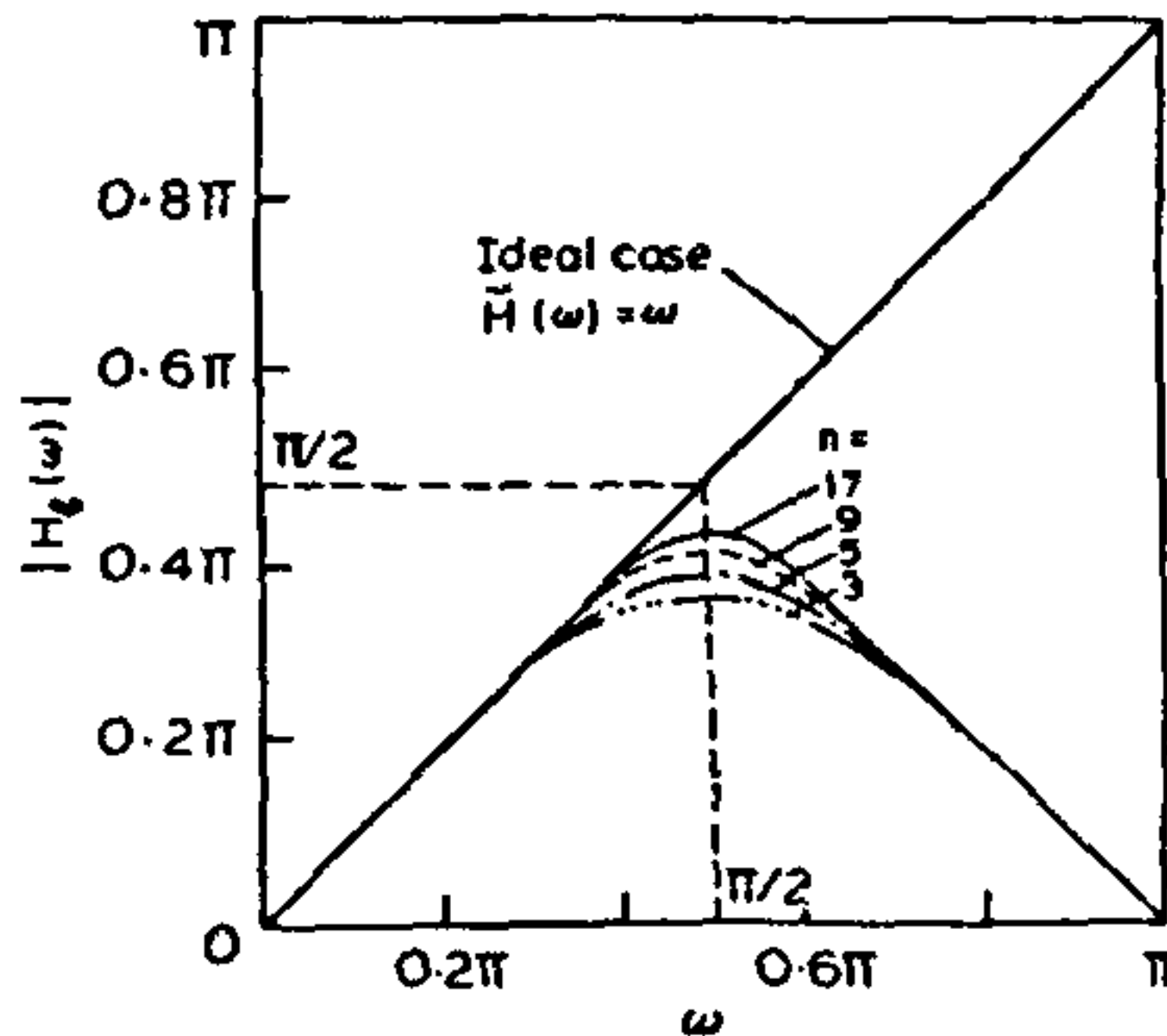

Figure 8. Frequency response $H_l(\omega)$ of variable frequency range DD at various output taps.

width operation; this is given by

$$H_l(\omega) = \sum_{\substack{i=1 \\ i \text{ odd}}}^n (-p_i) (\sin \omega)^i, \quad n = (N - 1)/2, N \text{ odd.} \quad (31)$$

For causal realization of (29), we take the transfer function as

$$G_m(z) = z^{-n} H_m(\omega) \Big|_{e^{j\omega} = z} = (\pi/2) z^{-n} + \sum_{\substack{i=1 \\ i \text{ odd}}}^n p_i z^{-n+i} \left(\frac{1+z^{-2}}{2} \right)^i. \quad (32)$$

Similarly, for $H_l(\omega)$ the causal transfer function is

$$G_l(z) = \sum_{\substack{i=1 \\ i \text{ odd}}}^n (-1)^{(i+1)/2} p_i z^{-n+i} \left(\frac{1-z^{-2}}{2} \right)^i. \quad (33)$$

Both $G_m(z)$ and $G_l(z)$ can be realized through a composite structure, as shown in figure 7. The outputs from taps numbered 1, 3, 5, ... correspond to those of differentiators with $n = 1, 3, 5, \dots$ respectively. The performances at various taps are illustrated in figures 8 and 3.

The variable bandwidth differentiator can be fabricated as a single chip and would be particularly useful in electronic scanning, beam steering and adaptive image enhancement.

ACKNOWLEDGEMENT

The work described here was done in collaboration with my Ph.D. student Balbir Kumar. Working with Balbir has been a pleasure, particularly because of his almost wizardly capability of negotiating difficult terrains of combinatorial mathematics.

1 December 1988

1. Rabiner, L. R. and Schafer, R. W., *Bell Syst. Tech. J.*, 1974, 53, 333.
2. Rabiner, L. R. and Gold, B., *Theory and applications of digital signal processing*, Prentice Hall, New Jersey, 1975.
3. Rabiner, L. R. and Steiglitz, K., *IEEE Trans. Audio Electroacoust.*, 1970, AU-18, 204.
4. Ahuja, S. S. and Dutta Roy, S. C., *Electron. Lett.*, 1978, 14, 422.
5. Ahuja, S. S. and Dutta Roy, S. C., *Proc. IEEE*, 1979, 67, 173.
6. Dutta Roy, S. C. and Ahuja, S. S., *IEEE Trans. Circuits Syst.*, 1979, CAS-26, 73.
7. Ahuja, S. S. and Dutta Roy, S. C., *Electron. Lett.*, 1979, 15, 245.
8. Ahuja, S. S. and Dutta Roy, S. C., *IEEE Trans. Circuits Syst.*, 1980, CAS-27, 836.
9. Jinaga, B. C. and Dutta Roy, S. C., *Proc. IEEE*, 1984, 72, 1092.
10. Jinaga, B. C. and Dutta Roy, S. C., *Signal Processing*, 1984, 7, 185.
11. Jinaga, B. C. and Dutta Roy, S. C., *Proc. IEEE*, 1985, 73, 1135.
12. Jinaga, B. C. and Dutta Roy, S. C., *Signal Processing*, 1985, 9, 121.
13. Dutta Roy, S. C. and Kumar, B., *A digital differentiator*, Patent Application, filed on 18th January 1988.
14. Kumar, B. and Dutta Roy, S. C., *Proc. IEEE*, 1988, 76, 287.
15. Kumar, B. and Dutta Roy, S. C., *Electron. Lett.*, 1988, 24, 563.
16. Kumar, B. and Dutta Roy, S. C., *Int. J. Circuit Theor. Applic.*, (to appear).
17. Kumar, B. and Dutta Roy, S. C., *Int. J. Circuit Theor. Applic.*, (to appear).
18. Kumar, B. and Dutta Roy, S. C., *IEEE Trans. Circuits Syst.* (under revision).
19. Kumar, B. and Dutta Roy, S. C., *IEEE Trans. Circuits Syst.*, (under review).